

PARTS AND OPERATION MANUAL

MULTIQUIP **Model GA-3.6RZ2** **A.C. GENERATOR**

© COPYRIGHT 2000, MULTIQUIP INC.

Revision #2 (03/05/01)



MULTIQUIP INC.

18910 WILMINGTON AVE.
CARSON, CALIFORNIA 90746
310-537-3700
800-421-1244
FAX: 310-537-3927

PARTS DEPARTMENT:

800-427-1244
FAX: 800-672-7877

SERVICE DEPARTMENT/TECHNICAL ASSISTANCE:

800-478-1244
FAX: 310-631-5032

E-mail: mq@multiquip.com • www.multiquip.com

Atlanta • Boise • Dallas • Houston • Newark
Montreal, Canada • Manchester, UK
Rio De Janeiro, Brazil • Guadalajara, Mexico



WARNING



CALIFORNIA — Proposition 65 Warning

Engine exhaust and some of its constituents are known to the State of California to cause cancer, birth defects and other reproductive harm.

HERE'S HOW TO GET HELP

*PLEASE HAVE THE MODEL AND SERIAL NUMBER
ON-HAND WHEN CALLING*

PARTS DEPARTMENT

800-427-1244 or 310-537-3700

FAX: 800-672-7877 or 310-637-3284

SERVICE DEPARTMENT/TECHNICAL ASSISTANCE

800-478-1244 or 310-537-3700

FAX: 310- 537-4259

WARRANTY DEPARTMENT

888-661-4279, or 310-661-4279

FAX: 310- 537-1173

MAIN

800-421-1244 or 310-537-3700

FAX: 310-537-3927

TABLE OF CONTENTS

Here's How To Get Help	3
Table Of Contents	4
Parts Ordering Procedures	5
Rules For Safe Operation	6
Operation and Safety Decals	7
Specifications	8
General Information	9

Multiquip GA-3.6RZ2 — AC Generator

Controls and Indicators	10
Installation	11
Pre-Setup	12-13
Instrumentation	14
Load Application	15
Operating Instructions	16
Maintenance	17
Preparation For Long Term Storage	18
Wiring Diagram	19
Troubleshooting (Engine)	20-21
Troubleshooting (Generator)	22-23
Explanation Of Codes In Remarks Column	24
Suggested Spare Parts	25
Generator Assembly	26-27
Control Box Assembly	28-29
Pipe Frame Assembly	30-31
Name Plate And Decals	32-33

ROBIN EH-25 Engine

Crankcase Assembly	34-35
Crankshaft & Piston Assembly	36-37
Intake & Exhaust Assembly	38-39
Governor Assembly	40-41
Cooling & Starting Assembly	42-43
Carburetor	44-45
Ignition Coil Assembly And Spark Plug	46-47
Fuel Strainer	48-49

Terms and Conditions Of Sale — Parts	50
--	----

NOTE

*Specification and part number
are subject to change without
notice.*

PARTS ORDERING PROCEDURES

- Dealer account number
- Dealer name and address
- Shipping address (if different than billing address)
- Return fax number
- Applicable model number
- Quantity, part number and description of each part
- Specify preferred method of shipment:
 - UPS Ground
 - UPS Second Day or Third Day*
 - UPS Next Day*
 - Federal Express Priority One (please provide us with your Federal Express account number)*
 - Airborne Express*
 - Truck or parcel post

**Normally shipped the same day the order is received, if prior to 2PM west coast time.*

Earn Extra Discounts when you order by FAX!

All parts orders which include complete part numbers and are received by fax qualify for the following extra discounts:

<u>Number of line items ordered</u>	<u>Additional Discount</u>
1-9 items	3%
10+ items**	5%

Get special freight allowances when you order 10 or more line items via FAX! **

- UPS Ground Service at no charge for freight
- PS Third Day Service at one-half of actual freight cost

No other allowances on freight shipped by any other carrier.

**Common nuts, bolts and washers (all items under \$1.00 list price) do not count towards the 10+ line items.

DISCOUNTS ARE SUBJECT TO CHANGE

Fax order discount and UPS special programs revised June 1, 1995

**Extra Fax Discount
for Domestic USA
Dealers Only**

**Up to 5%
extra savings!**

**UPS
Special**
For faxed orders only

**Now! Direct TOLL-FREE access
to our Parts Department!**

Toll-free nationwide:

800-421-1244

Toll-free FAX:

800/6-PARTS-7 • 800-672-7877

CAUTION:



Failure to follow instructions in this manual may lead to serious injury or even death! This equipment is to be operated by trained and qualified personnel only! This equipment is for industrial use only.

The following safety guidelines should always be used when operating the GA-3.6RZ2 Generator:

GENERAL SAFETY

- **DO NOT** operate or service this equipment before reading this entire manual.
- This equipment should not be operated by persons under 18 years of age.
- **NEVER** operate this equipment without proper protective clothing, shatterproof glasses, steel-toed boots and other protective devices required by the job.
- This generator is a source of providing **LETHAL** high voltages. Never permit unqualified personnel—especially children to operate the generator.
- Always refuel in a well-ventilated area, away from sparks and open flames.
- Always use extreme caution when working with **flammable** liquids. When refueling, **stop the engine** and allow it to cool. **DO NOT** smoke around or near the machine. Fire or explosion could result from flames or sparks, or if fuel is spilled on a hot engine.
- This generator is equipped with a **ground terminal** for your protection. Always complete the grounding path from the generator to an external grounding source.
- **NEVER** operate this generator, or handle any electrical equipment while standing in **water, while bare foot, while hands are wet, or in the rain**. *Dangerous electrical shock could occur causing severe bodily harm or even death.*
- Keep electrical cords in good condition. Worn, bare or frayed wiring can cause electrical shock, thus causing *bodily harm or even death*.
- This generator requires an adequate free flow of cooling air. Never operate the generator in any enclosed or narrow area where free flow of the air is restricted. If the air flow is restricted it will cause serious damage to the generator and may cause injury to people.
- **NEVER** touch the hot exhaust manifold, muffler or cylinder. Allow these parts to cool before servicing generator.

- Provide adequate ventilation when operating the generator. **DO NOT** operate the generator in any enclosed or narrow space. The generator's gasoline engine gives off **DEADLY** monoxide gas.
- **NEVER** operate the generator in an explosive atmosphere or near combustible materials. An explosion or fire could result causing severe *bodily harm or even death*.
- Always make sure that the generator is secure on level ground so that it cannot slide or shift around, endangering workers. Also keep the immediate area free of bystanders.

CAUTION:



- **High Temperatures** – Allow the machine and engine to cool before adding fuel or performing service and maintenance functions. Contact with *hot* components can cause serious burns.

CAUTION:



Emergencies

- Always know the location of the nearest **fire extinguisher** and **first aid kit**. Know the location of the nearest telephone. Also know the phone numbers of the nearest **ambulance, doctor** and **fire department**. This information will be invaluable in the case of an emergency.

Maintenance Safety

- **NEVER** lubricate components or attempt service on a running machine.
- Always allow the machine a proper amount of time to cool before servicing.
- Keep the machinery in proper running condition.
- Fix damage to the machine immediately and always replace broken parts.
- Dispose of hazardous waste properly. Examples of potentially hazardous waste are used motor oil, fuel and fuel filters.
- **DO NOT** use food or plastic containers to dispose of hazardous waste.
- **DO NOT** pour waste, oil or fuel directly onto the ground, down a drain or into any water source.

OPERATION AND SAFETY DECALS

Machine Safety Decals

The GA-3.6RZ2 portable generator is equipped with a number of safety decals. These decals are provided for operator safety and maintenance information. The illustration below shows these decals as they appear on the machine. Should any of these decals become unreadable, replacements can be obtained from your dealer.



P/N 7910631002



P/N 7900636004

OPERATING INSTRUCTIONS

1. Before starting check the oil and fuel level.
2. Switch the circuit breaker to the "OFF" position.
3. Open the fuel valve.
4. Pull the choke knob.
5. Turns the operation switch to the "RUN" position and push
6. Pull the recoil starter.
7. After the engine starts, gradually push in the choke valve.
8. Run the generator for 3-5 minutes without load.
9. Check for any abnormal noise or smell.
10. Switch the circuit breaker to the "ON" position.
11. When stopping, remove the load and allow it to continue to run for 2-3 minutes before stopping engine.
2. Turns the operation switch to the "STOP" position.
3. After the engine completely stops, close the fuel valve.

P/N 7900638204

S-4607



P/N 8700611904

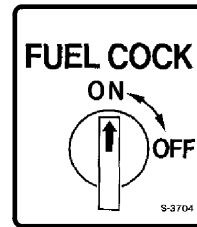

P/N 1980680004

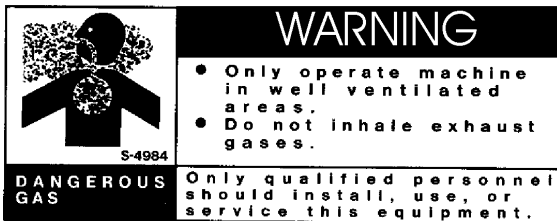

P/N 8700611804

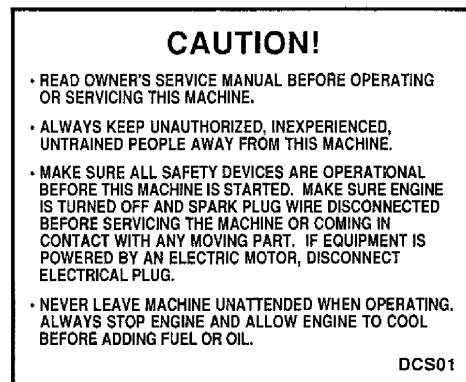

P/N 0820610804

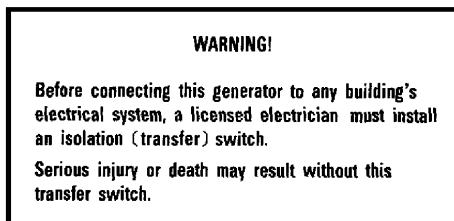

P/N 0820610404



P/N 0800628504

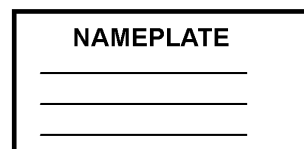

CONTACT MULTIQUIP SERVICE DEPT.

Table 1. Specifications

MODEL		GA-3.6RZ2
	Type	2-pole, Brushless Type Revolving Field
Generator	Max. Output	3600 Watts
	Rated Output (continuous)	3200 Watts
	Rated Voltage	120V/240V
	Phase	Single Phase (4-wire)
	Frequency	60 Hz
	Rated Speed	3600 RPM
	Power Factor	100%
Engine	Model	Robin EH-25
	Type	Air-cooled 4 cycle, vertical OVH type, gasoline engine
	Number of cylinders	1
	Bore X Stroke	1-2.95 in x 2.24 in
	Displacement	15.32 cc
	Max Output	8 H.P./3600 R.P.M.
	Fuel Tank Capacity	Approx. 5 U.S. Gallons
	Fuel	Unleaded Automobile Gasoline
	Lube Oil Capacity	2-1/8 pints
	Speed Control Method	Centrifugal Fly-weight Type
	Starting Method	Recoil Start
Dimension (LXWXH)		605X 420 X 570 mm (23.8 in X 16.5 in X 22.4)
Dry Net Weight		140 lbs (64kg)

Effects of Altitude and Heat

The maximum output of the engine listed above is applicable to supplying electrical power for continuous service at ambient conditions in accordance with SAE Test cord J607. The above ambient conditions are at standard sea level, with a barometric reading of 29.92 inches and a temperature of 60 degrees fahrenheit.

Generally, the engine output power will decrease 3 1/2% for each 1000 feet of altitude above sea level, and 1% for each 10° F fahrenheit above the standard temperature of 60° F

GA-3.6RZ2 FAMILIARIZATION

Generator

The Multiquip Model GA-3.6RZ2 generator has been designed as a portable lightweight power source for 60 Hz (single-phase) vibrators, lighting facilities, power tools, sersmersible pumps and other industrial and construction machinery.

This generator employs the highly reliable **ROBIN** engine. The alternator, a brushless revolving-field type, single phase is permanently aligned to the engine through rigid coupling.

The entire generator is mounted on rubber vibration isolators that have a steel base backplate which is attached to the protective steel pipe carrying frame. The protective carrying frame is made of steel tubing and fully wraps around the generator to protect against damage.

This portable generator is supplied with a electrical **control box**. To reduce vibration caused by the engine, the control box is also placed on rubber isolators.

Control Box

The control box has the following: (outputs are 60 Hz, single phase)

- One 120V output receptacle.
- One 240V output receptacle.
- One 120V output receptacle (GFCI protected).
- One main 13.5 amp circuit breaker.
- AC Voltmeter
- Idle Control Switch
- Full Power Switch
- Ground Terminal

Excitation System

All GA-series generators use a magnet attached to a flywheel to produce AC voltage from a lamp coil beneath the flywheel. As the magnetic passes the coil it produces approximately 19-22 AC volts.

This voltage (19-22 VAC) is then sent to the control box that contains three rectifying diodes:

- Excitation (diode 1)
- Battery (diode 2)
- Slow Down (diode 3)

The AC voltage will pass through the excitation diode that converts the voltage to DC power.

This DC power is then sent to the excitation windings housed within the main windings commonly called the "stator".

This voltage is then transferred into the rotor through induction. The rotor contains two diodes within it which rectify the DC voltage and send it out through the main windings, as AC voltage.

Engine

The four-cycle air-cooled ROBIN gasoline engine is designed to meet every performance requirement of this generator. Reference Table 1, page 8 for engine specifications

In keeping with Multiquip's policy of constantly improving its products, the specifications quoted herein are subject to change without prior notice.

Figure 1 (page 10) shows the basic controls and indicators for the GA-3.6RZ2 generator.

GA-3.6RZ2 — CONTROLS AND INDICATORS

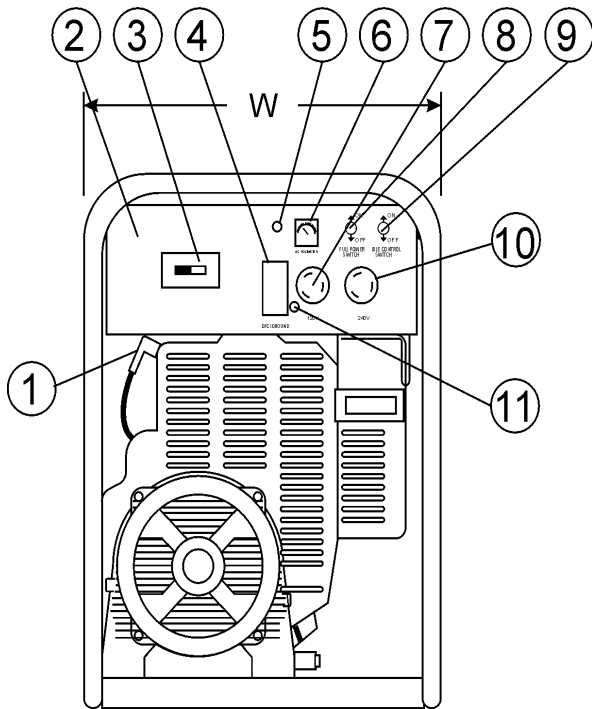

NO.	PARTS NAME
1	SPARK PLUG
2	CONTROL BOX
3	CIRCUIT BREAKER
4	RECEPTACLE (120V, GFCI)
5	OIL ALARM LAMP
6	AC VOLTMETER
7	RECEPTACLE (125V)
8	FULL POWER SWITCH
9	IDLE CONTROL SWITCH
10	RECEPTACLE (250V) OIL
11	GROUND TERMINAL
12	FUEL TANK
13	AIR CLEANER
14	MUFFLER
15	STARTING KNOB
16	DRAIN PLUG

L	W	H
23.8 IN. 605 MM	16.5 IN. 420 MM	22.4 IN. 570 MM

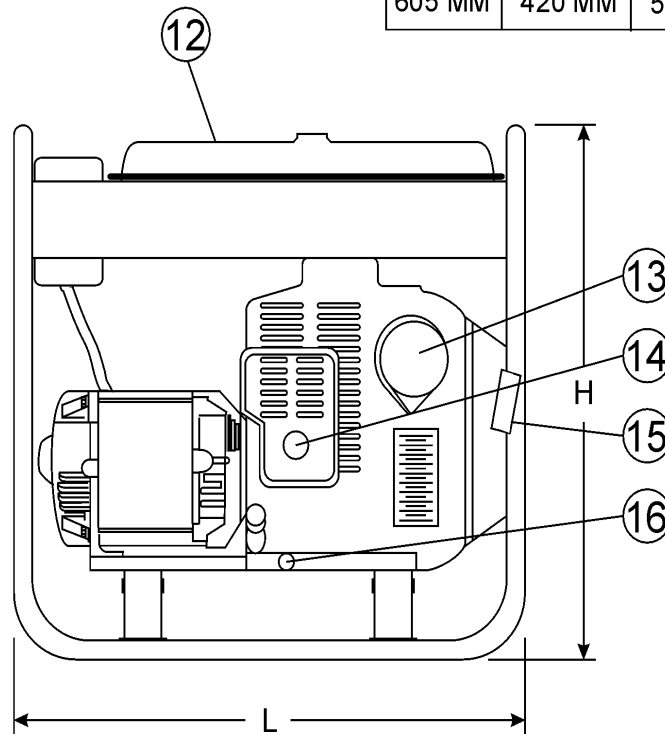

Figure 1. Controls and Indicators

Outdoor Installation

Install the generator in a location where it will not be exposed to rain or sunshine. Make sure that the generator is on secure level ground so that it cannot slide or shift around. Also install the generator in a manner so that the exhaust will not be discharged in the direction of nearby homes.

The installation site must be relatively free from moisture and dust. All electrical equipment should be protected from excessive moisture. Failure to do so will result in deterioration of the insulation and will result in short circuits and grounding.

Foreign materials such as dust, sand, lint and abrasive materials have a tendency to cause excessive wear, not only to the engine parts, but also to the alternator parts.

CAUTION :



Pay close attention to ventilation when operating the generator inside tunnels and caves. The engine exhaust contains noxious elements.

Indoor Installation

Exhaust gases from gasoline engines are extremely poisonous. Whenever an engine is installed indoors the exhaust fumes must be vented to the outside. The engine should be installed at least two feet from any outside wall. Using an exhaust pipe which is too long or too small can cause excessive back pressure which will cause the engine to heat excessively and possibly burn the valves.

Eliminate the danger of deadly carbon monoxide gas. Remember that exhaust fumes from any gasoline engine are very poisonous if discharged in a closed room, but harmless if allowed to mix with the outside air. If the generator is installed indoors, you must make provisions for venting the engine exhaust to the outside of the building.

CAUTION :



An electric shock is apt to happen when vibrators are used. Pay close attention to handling when operating vibrators and always use rubber boots and gloves to insulate the body from a short circuit.

General Inspection Prior to Operation

This generator has been thoroughly inspected and accepted prior to shipment from the factory. However, be sure to check for damaged parts or components, or loose nuts and bolts, which could have occurred in transit.

Ground

The nut and ground terminal on the generator should always be used to connect the generator to a suitable ground. The ground path should be of #8 size wire.

Connect the terminal of the ground wire between the lock washer and the nut and tighten the nut fully. Connect the other end of this wire to a suitable ground.

Circuit Breaker

A 2-pole, 13.5 amp circuit breaker is provided on the control box to protect the generator from an overload. Make sure to switch the circuit breakers to the "OFF" position prior to starting the engine.

Extension Cable

When electric power is to be provided to various tools or loads at some distance from the generator, extension cords are normally used. Cables should be sized to allow for distance in length and amperage so that the voltage drop between the generator and point of use (load) is held to a minimum. Use the cable selection chart (Table 2) as a guide for selecting proper cable size.

Table 2. Cable Selection (60 Hz, single phase operation)

Current in Amperes	Load In Watts		Maximum Allowable Cable Length			
	At 120 Volts	At 240 Volts	#10 Wire	#12 Wire	#14 Wire	#16 Wire
2.5	300	600	1000 ft.	600 ft.	375 ft.	250 ft.
5	600	1200	500 ft.	300 ft.	200 ft.	125 ft.
7.5	900	1800	350 ft.	200 ft.	125 ft.	100 ft.
10	1200	2400	250 ft.	150 ft.	100 ft.	
15	1800	3600	150 ft.	100 ft.	65 ft.	
20	2400	4800	125 ft.	75 ft.	50 ft.	

CAUTION: Equipment damage can result from low voltage.

Lubrication Oil

Fill the engine crankcase with lubricating oil through the filler hole, but do not overfill. Make sure the generator is level. With the dipstick inserted all the way, but without being screw into the filler hole, verify that the oil level is maintained between the two notches on the dipstick.

The oil listed in Table 3 is recommended to ensure better engine performance. Use class SC or higher grade motor oil.

NOTE

This ROBIN engine is equipped with a low oil shutdown capability. A built in sensor will automatically turn off the engine should the oil level fall below a safe operating condition. Make sure the generator is placed on level ground. Placing the generator on level ground will ensure that the low oil sensor will function properly.

Fuel

Close the fuel cock before filling the tank. Fill the fuel tank with clean and fresh unleaded gasoline. Do not fill the tank beyond capacity.

Pay attention to the fuel tank capacity when replenishing fuel. Refer to the fuel tank capacity listed on page 8 Specification Table1.

The fuel tank cap must be closed tightly after filling.

Handle fuel in a safety container. If the container does not have a spout, use a funnel.

CAUTION :



Never fill the fuel tank while the engine is running or in the dark. Gasoline spillage on a hot engine can cause a fire or explosion. If gasoline spillage occurs, wipe up the spilled gasoline completely to prevent fire hazards.

Table 3. Recommended Motor Oil

Temperature Range	Type Oil
104° F ~ 23° F (40° C ~ -5°C)	SAE 30
23° F ~ 5° F (-5° C ~ -15°C)	SAE 20 or sae 10W-30
Below 5° C (-15°)	SAE 10W or SAE 10W-30

CAUTION :



When using a combination of dual receptacles, total load should not exceed the rated capacity of the generating.

Power Outlets

The generator has the following 120/240 volt 60 Hz (single-phase) receptacles.

- Single Phase
 - One Duplex NEMA (GFCI) 5-20R (120V, 20 Amp)
 - One Twist Lock NEMA L5-30R (120V, 30 Amp)
 - One Twist Lock NEMA L6-20R (240V, 20 Amp)

Main Circuit Breaker (2-Pole 120/240V 60 Hz)

This 2-pole 21 amp breaker protects the generator from short circuiting or overloading from the 120/240V 60 Hz single phase load.

Idle Control Switch

This unit is provided with an automatic idle control for noise suppression and reduced fuel consumption. The automatic idle control automatically engages under a no-load condition. With the automatic idle control switched "ON", the engine revolutions will automatically drop to about 2600 rpm (low-speed operation) within 3 seconds after the load stops. When the operation is resumed, the engine speed is automatically increased to about 3600 rpm (high-speed operation) as soon as the load is connected.

Fuel Gauge

The fuel gauge is located on the fuel tank and allows easy monitoring of the fuel level.

AC Voltmeter

This voltmeter indicates (with a mark) the rated 60 Hz, single phase output voltage. In addition the voltmeter can also be used as a diagnostic tool.

If the voltmeter indicator (needle) is below the rated voltage, engine problems may exist (low/high RPM's). To prevent damage to the generator or power tools turn the generator OFF and consult your authorized Multiquip service dealer.

Operation Switch

This switch must be in the ON position (up) for normal operation.

Start Switch

Push this switch to start the engine (electric start only). If a recoil starter is used, pull the starter rope to start the engine. Make sure the operation switch is in the ON position (up), otherwise engine will not start.

Full Power Switch

The unit is provided with a full power switch. Figures 2 and 3 show simplified wiring diagrams of the dual voltage system.

When the full power switch is in the 120 volt (up) position, you can take up **full rated power** of the generator at 120 volts from the single duplex receptacle, single locking type 120 volt receptacle, or a combination of these receptacles as long as the total load does not exceed the generating set capacity.

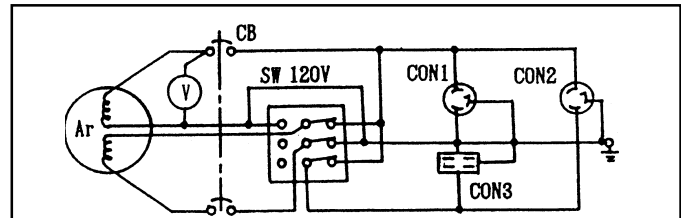

Figure 2. 120 V Simplified Diagram (Switch Up)

NOTE

When the full power switch is in the 120 volt position, the locking type 240 volt receptacle cannot be used.

When the full power switch is in the 240 volt (down) position, you can take up to half of the rated power of the generating set at 120 volts from the duplex receptacle and up to half of the rated power of the set at 120 volts from the locking type 120 volt receptacle; or full rated power of the set at 240 volts from the locking type 240 volt receptacle.

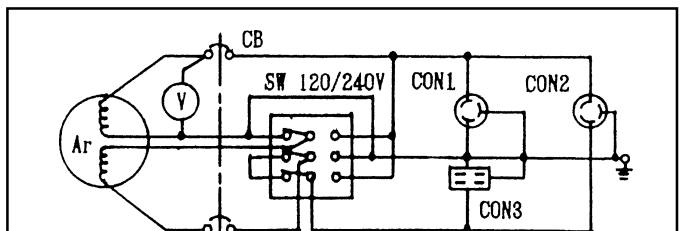

Figure 3. 240 V Simplified Diagram (Switch Dn.)

Single Phase Load

Always be sure to check the nameplate on the generator and equipment to insure the wattage, amperage and frequency requirements are satisfactorily supplied by the generator for operating the equipment.

Generally, the wattage listed on the nameplate of the equipment is its rated output. Equipment may require 130—150% more wattage than the rating on the nameplate, as the wattage is influenced by the efficiency, power factor and starting system of the equipment.

NOTE

If wattage is not given on the equipment's name plate, approximate wattage may be determined by multiplying nameplate voltage by the nameplate amperage.

WATTS = VOLTAGE x AMPERAGE

To determine the running wattage for your load, multiply the running wattage as indicated by steps 1, 2, and 3 below:

- 1. INCANDESCENT LOADS**
Lights, heaters and similar appliances.
Total the running wattage and multiply by 1.
Example:
29 light bulbs @ 100W each = 2.9 KW
use a 3 KW generator.
- 2. SMALL MOTORS**
Drills and other small power tools.
Total the running wattage and multiply by 2.
Example:
A 1 inch drill runs at 1 KW
use a 2 KW generator.
- 3. LARGE MOTORS**
Submersible pumps, table saws etc.
Total the running wattage and multiply by 3.
Example:
A conveyor belt runs at 8 KW
use a 24 KW generator.

CAUTION:



Motors and motor-driven equipment draw much greater current for starting than during operation.

An inadequate size connecting cable which cannot carry the required load can cause a voltage drop which can burn out the appliance or tool and overheat the cable.

The idle control is operated at minimum load capacity of 100W. If the load capacity is less than 100W, throw the idle control switch to the OFF position.

Before Starting

1. Be sure to disconnect the electrical load and switch the main circuit breaker to the "OFF" position prior to starting the engine.
2. Never start the engine with the main circuit breaker "ON".
3. Check the lubricating oil level prior to starting the engine. Make sure the generator is level. The oil level must be maintained between two notches on the dipstick.
4. When there is not enough lubricating oil, fill the crankcase with high grade motor oil. Use a high quality detergent oil classified SC, SD or SE. (See Table 3 on page 13)

CAUTION:



- NEVER start the engine when the oil level is below the lower mark on the dipstick.
- Check the fuel level on the fuel gauge. When fuel is low, fill the fuel tank with clean fresh unleaded automotive gasoline.
- If gasoline spillage occurs, completely wipe up the spilled gasoline.

Starting

1. Open the fuel cock located below the fuel tank. The fuel starts to flow when the fuel cock lever is turned downward.
2. Place the idle control switch in the "ON" (up) position.
3. Close the choke. Adjust the opening of the choke valve according to operating conditions. When the engine is warm or the air temperature is high, close the choke valve halfway or open it all the way.
4. Confirm that the main circuit breaker on the generator control box is "OFF".
5. Set the operation switch to the "ON" position and grasp the starting knob and slowly pull it out. The resistance becomes hardest at a certain position, corresponding to the compression point. Rewind the rope a little from that point and pull out sharply.
6. If the engine fails to start, repeat the procedure.

CAUTION:



- DO NOT pull the starter rope all the way to the end.
- DO NOT release the starter knob after pulling. Allow it to rewind as soon as

Warm up

1. When the engine starts, open the choke slowly.
2. Run the engine at low speed for 3 minutes without load until the engine warms up.
3. Turn the idle control switch to the "OFF" (down) position and check the voltage by referring to the voltmeter on the control box.

CAUTION:



DO NOT change the engine speed control lever which has been set at the factory prior to shipping.

1. Check the generator for abnormal noise and smells. Then connect the load to the receptacles of the generator.
2. Switch the main circuit breaker to the "ON" position and turn the idle control switch to the "ON" (down) position for normal (load) engine operation.

Operation

Check the voltage by referring to the voltmeter on the control box. When the voltmeter indicates 120 volts, 120 volts from the 120V receptacle can be obtained. Refer to Figure 1, Controls and Indicators, item 5 on page 10.

Stopping the Engine

CAUTION:



NEVER stop the engine suddenly while running at high speeds.

1. Remove the load from the generator. Place the circuit breaker in the "OFF" position. Refer to Figure 1, item 2 on page 10. Run the engine (no-load) with the idle control switch set to the ON position for three to five minutes, then stop the engine.
2. Turn the START/STOP switch to the "STOP" position.
3. Close the fuel cock.

General Inspection

At least daily or prior to each use, the generating set should be cleaned and inspected for deficiencies. Check for loose, missing or damaged nuts, bolts or other fasteners. Also check for fuel or oil leaks.

Engine Side (Refer to the Engine Instruction Manual)

Check Oil Level

Check the crankcase oil level prior to each use, or when the fuel tank is filled. Make sure the generating set is level. The oil level must be between the two notches on the dipstick.

Changing Oil

Change oil after the first 20 hours of operation. Drain and refill the engine crankcase every 50 operating hours or once a week thereafter. Drain crankcase oil into a suitable container while engine is still warm. Replace the drain plug tightly. Add oil through the filler hole.

Air Cleaner

Every 50 hours: Remove air cleaner element (std. or heavy duty types), and wash in kerosene or liquid detergent and hot water. Wrap foam element in a cloth and squeeze dry. Wipe heavy duty paper element dry with toweling. Saturate element with kerosene; squeeze excess from foam element. Wipe excess from heavy duty paper element.

Service Daily

If engine is operating in very dusty and dry grass conditions. A clogged air cleaner will result in high fuel consumption, loss of power and excessive carbon buildup in the combustion chamber.

Cleaning the Fuel Strainer

Clean the fuel strainer if it contains dust or water. Remove dust or water in the strainer cap and wash it in gasoline. Securely fasten the fuel strainer cap so that fuel will not leak. Check the fuel strainer every 200 hours of operation or once a month.

Spark Plug

Remove carbon build-up on the spark plug (Figure 4) with a wire brush. Set the spark plug gap to 0.6—0.7mm (0.024-0.028 inch). Tighten with a spark plug socket wrench. Clean the spark plug every 50 operating hours or once a week.

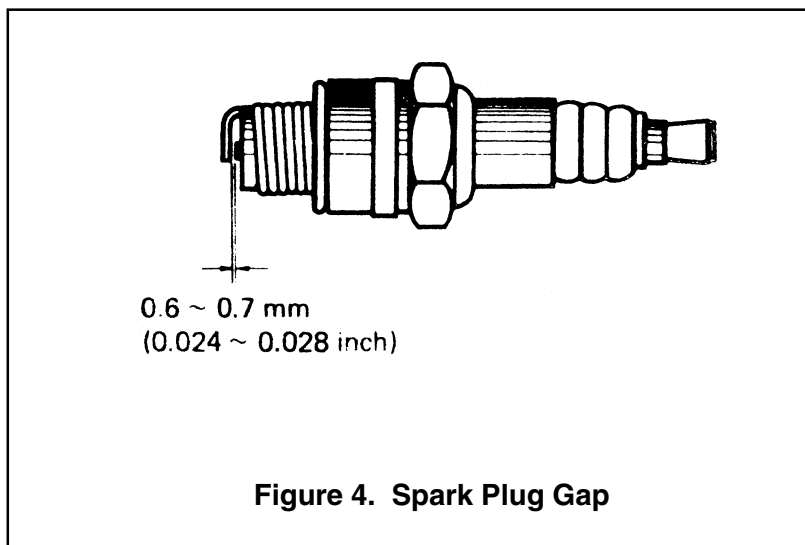

Figure 4. Spark Plug Gap

GA-3.6RZ2 — PREPARATION FOR LONG -TERM STORAGE

Generator Storage

For storage of the generating set for over 30 days, the following is required:

- Drain the fuel tank completely.
- Run the engine until the gasoline in the carburetor is completely consumed.
- Completely drain the oil from the crankcase and refill with fresh oil.
- Remove the spark plug, pour 2 or 3 cc of SAE 30 oil into the cylinder and crank slowly to distribute the oil.
- Slowly rotate the engine a few times with the starter Rope and install a new plug.
- Pull out the starter rope slowly and stop at the compression point.
- Clean all external parts of the generating set with a cloth.
- Cover the generating set and store in a clean, dry place.

GENERATOR

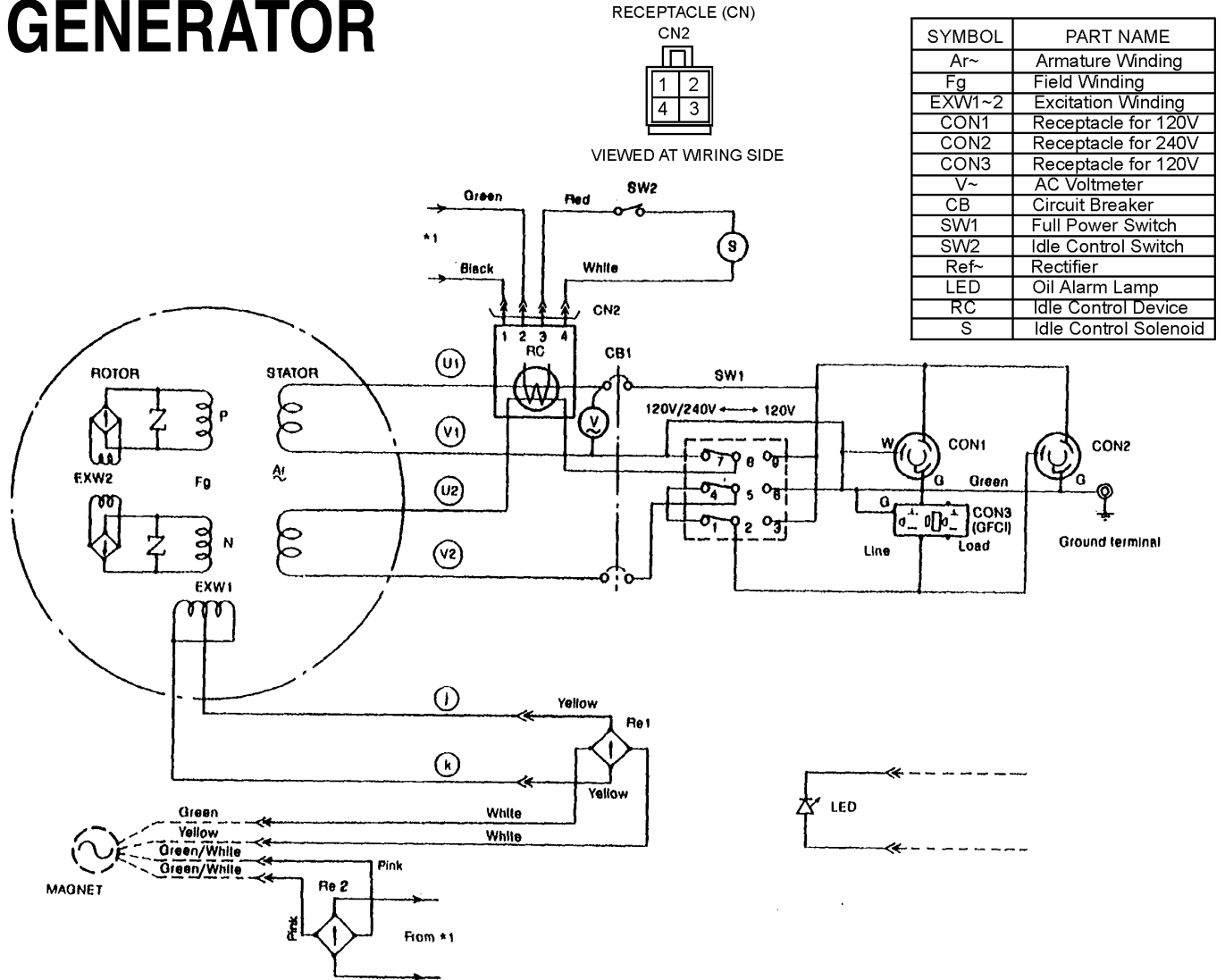

ENGINE

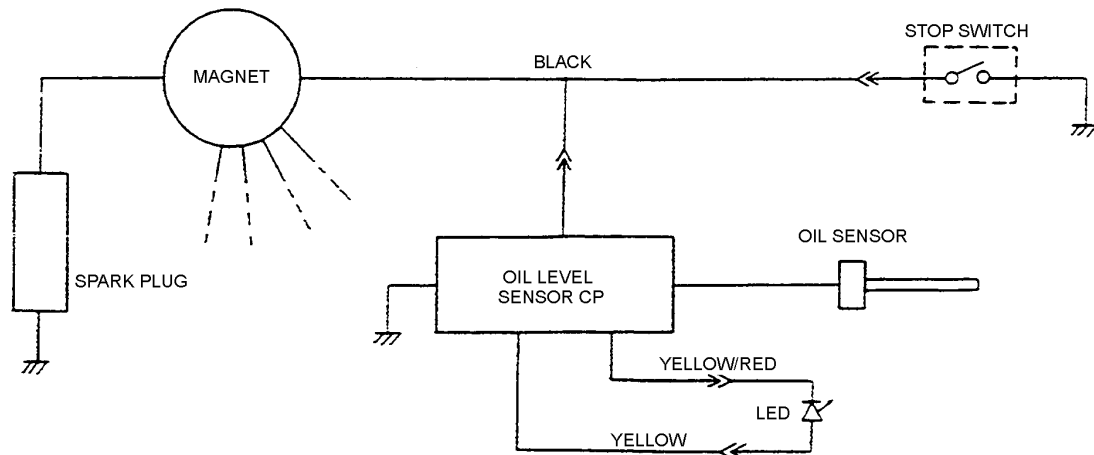

GA-3.6RZ2 — TROUBLESHOOTING (ENGINE)

Practically all breakdowns can be prevented by proper handling and maintenance inspections, but in the event of a breakdown, please take a remedial action following the

diagnosis based on the Engine Troubleshooting (Table 4) information shown below and on the proceeding page. If the problem cannot be remedied, please leave the unit just as it is and consult our company's business office or service plant.

TABLE 4. ENGINE TROUBLESHOOTING

SYMPTOM	POSSIBLE PROBLEM	SOLUTION
Poor starting	Inspect carburetor to see if fuel is reaching it?	Check fuel line
	No Fuel?	Add Fuel
	Water in fuel tank?	Flush or replace fuel tank.
	Fuel filter clogged?	Replace fuel filter
	Stuck carburetor?	Check float mechanism.
	Spark plug is red?	Spark plug is fouled. Check transistor ignition unit.
	Spark plug is blue-white?	Insufficient compression, injected air leaking. Carburetor jets are clogged (overflow).
	No spark present at tip of spark plug?	Transistor ignition unit broken, high voltage cord cracked or broken. Start/Stop switch broken. Replace spark plug if fouled.
	No oil?	Add oil as required.
	Oil pressure alarm lamp blinks upon starting?	Check Automatic shutdown circuit "oil sensor".
Insufficient power output "no compression"	Engine will not turn over?	Replace cylinder and piston and if necessary axel joint.
	Cylinder head connecting bolts loose?	Tighten cylinder head connecting bolts.
	Cylinder head gasket damaged?	Replace cylinder head gasket.
	Malfuction of valve seat?	Re-seat valves.
	Spark plug is loose?	Replace spark plug.
	Worn piston rings?	Replace piston rings.
Insufficient power output "compression"	Malfuction in air-cleaner system, air filter clogged?	Clean or replace air filter.
	Air leaking in from interface between carburetor and cylinder head?	Tighten bolts between carburetor and cylinder head. Replace cylinder head gasket.
	Malfuction in fuel system?	Clean or replace fuel filter. Clean or replace carburetor. Check carburetor float.

GA-3.6RZ2 — TROUBLESHOOTING (ENGINE)

TABLE 4. ENGINE TROUBLESHOOTING (CONTINUED)

SYMPTOM	POSSIBLE PROBLEM	SOLUTION
Insufficient power output "compression" and overheats	Malfunction in cooling fan?	Check or replace cooling fan.
	Air in-take filter clogged?	Clean or replace air in-take filter.
Burns to much fuel	Over accumulation of exhaust products?	Clean and check valves. Check muffler, replace if necessary.
	Wrong spark plug?	Replace spark plug with manufactures suggested type spark plug.
Exhaust color is continiously "WHITE"	Lubricating oil is wrong viscosity?	Replace lubricating oil with correct viscosity.
	Worn rings?	Replace rings
Exhaust color is continiously "BLACK"	Air cleanner clogged?	Clean or replace air cleaner.
	Choke valve has not been set to the correct position?	Adjust choke valve to the correct position.
	Carburetor defective, seal on carburetor broken?	Replace carburetor or seal.
	Poor carburetor adjustment "engine runs too rich?"	Adjust carburetor.

GA-3.6RZ2 — TROUBLESHOOTING (GENERATOR)

Practically all generator breakdowns can be prevented by proper handling and maintenance inspections, but in the event of a breakdown, please take a remedial action following the

diagnosis based on the Generator Troubleshooting (Table 5) information shown below and on the preceding page. If the problem cannot be remedied, please leave the unit just as it is and consult our company's business office or service plant.

TABLE 5. GENERATOR TROUBLESHOOTING

SYMPTOM	POSSIBLE PROBLEM	SOLUTION
Low voltage	Engine speed too low?	Raise engine speed to rated RPM.
Low voltage. Engine speed normal 3650 RPM (unloaded), 2500 RPM (idle)	AC voltmeter not working?	Replace AC voltmeter.
	Control box internal wiring malfunction?	Check control box wiring.
	Defective ignition coil?	Check red and green ignition wires. Replace ignition wires if necessary.
	Rotor winding malfunction?	Check or replace rotor.
	Stator winding malfunction?	Check or replace stator.
	Breaker malfunction?	Check or replace CB1.
	Full power switch malfunction?	Check full power switch and full power switch circuit.
Voltage output too high.	Engine speed too high?	Lower engine speed to rated RPM.
Voltage output too high. Engine speed normal 3650 RPM (unloaded), 2500 RPM (idle)	Control box internal wiring malfunction	Check control box wiring.
Circuit breaker will not turn on "NO LOAD"	Defective circuit breaker?	Replace circuit breaker.
Circuit breaker will turn on "LOADED" but trips immediately.	Overload?	Reduce load or replace breaker.
	Load circuit is shorted?	Check load circuit for short.
Does not accelerate from low to high "NO LOAD"	Stuck solenoid?	Check solenoid.
	Bad Idle control switch?	Check or replace idle control switch.
Does not accelerate from low to high "LOAD ACTIVE"	Idle control switch malfunction?	Check or replace idle control switch.
	Idle control device malfunction?	Check or replace idle control device.
	Control box internal wiring defective?	Check control box wiring.

GA-3.6RZ2 — TROUBLESHOOTING (GENERATOR)

TABLE 5. GENERATOR TROUBLESHOOTING (CONTINUED)

SYMPTOM	POSSIBLE PROBLEM	SOLUTION
Does not decelerate no "VOLTAGE OUTPUT".	Defective rotor windings?	Check or replace rotor.
	Defective solenoid?	Check or replace solenoid.
	Defective idle control device?	Check or replace idle control device.
	Defective solenoid?	Check or replace idle control device.
Does not decelerate but has "VOLTAGE OUTPUT".	Control box wiring malfunction?	Check control box wiring, replace any defective components.
	Defective solenoid?	Check or replace solenoid.
	Idle control device malfunction?	Check or replace idle control device.

GA-3.6RZ2 — EXPLANATION OF CODE IN REMARKS COLUMN

How to read the marks and remarks used in this parts book.

Items Found In the “Remarks” Column

Serial Numbers-Where indicated, this indicates a serial number range (inclusive) where a particular part is used.

Model Number-Where indicated, this shows that the corresponding part is utilized only with this specific model number or model number variant.

Items Found In the “Items Number” Column

All parts with same symbol in the number column, *, #, +, %, or ■, belong to the same assembly or kit.

NOTE

If more than one of the same reference number is listed, the last one listed indicates newest (or latest) part available.

NOTE

The contents of this catalog are subject to change without notice.

GA-3.6RZ2 — SUGGESTED SPARE PARTS

GA-3.6RZ2 WITH ROBIN EH-25 ENGINE

1 to 5 Units

Qty.	P/N	Description
1	0601805327	CIRCUIT BREAKER
1	0601811031	RECEPTACLE, GFCI
1	0601812597	RECEPTACLE, 125V, 30A
1	0601811032	RECEPTACLE, 250V, 20A
1	0601823204	RECTIFIER
1	0810106004	CAP, FUEL TANK
2	0810107103	FUEL FILTER, STRAINER
1	0605510024	FUEL COCK
5	2343260407	ELEMENT, AIR CLEANER ROUND
5	2343600203	ELEMENT, AIR CLEANER RECT.
5	0650140150	SPARK PLUG
1	KS31102301	OIL SENSOR
1	0669900217	SWITCH, ON/OFF

5 to 10 Units

Qty.	P/N	Description
2	0601805327	CIRCUIT BREAKER
2	0601811031	RECEPTACLE, GFCI
2	0601812597	RECEPTACLE, 125V, 30A
2	0601811032	RECEPTACLE, 250V, 20A
2	0601823204	RECTIFIER
2	0810106004	CAP, FUEL TANK
4	0810107103	FUEL FILTER, STRAINER
2	0605510024	FUEL COCK
10	2343260407	ELEMENT, AIR CLEANER ROUND
10	2343600203	ELEMENT, AIR CLEANER RECT.
10	0650141030	SPARK PLUG
2	KS31102301	OIL SENSOR
2	0669900207	SWITCH, ON/OFF
1	0601823853	SLOWDOWN UNIT
1	0601800258	AC VOLTMETER
1	0601810695	OIL ALARM LAMP
2	7895419004	RUBBER SUSPENSION
4	7685115504	RUBBER SUSPENSION
1	2545020100	RECOIL STARTER ASSY.
1	2536240400	CARBURETOR ASSY.
1	2547943011	IGNITION COIL

NOTE

Part numbers on this Suggested Spare Parts List may supercede/replace the P/N shown in the text pages of this book.

GENERATOR ASSY.

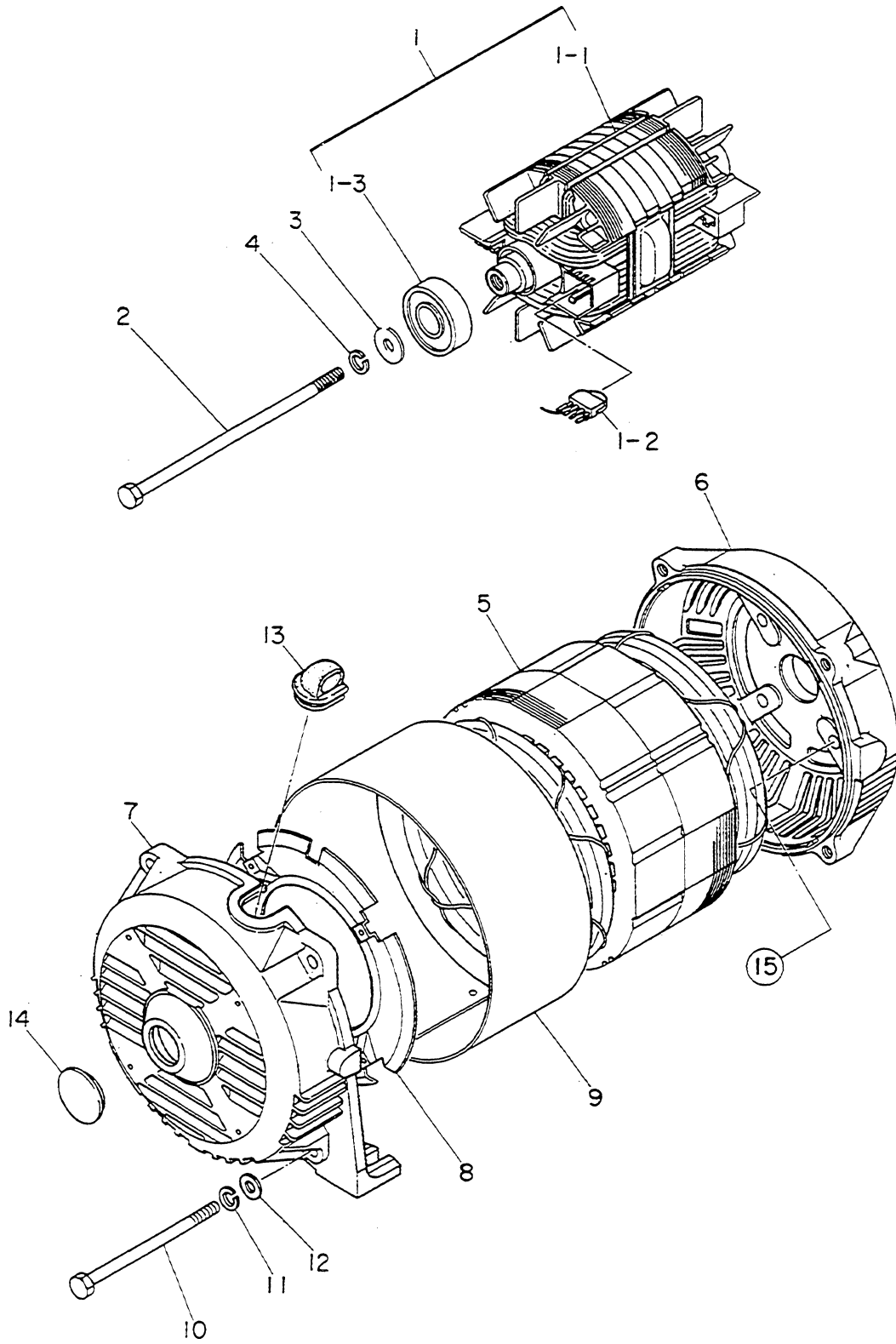

GENERATOR ASSY.

<u>NO</u>	<u>PART NO</u>	<u>PART NAME</u>	<u>QTY.</u>	<u>REMARKS</u>
1	7911000403	ROTOR ASSY.	1	INCLUDES ITEMS W/*
1-1*	7661080003	FIELD COIL	1	
1-2*	0601823207	RECTIFIER	2	D3SB60(S)
	0601822636	SURGE ABSORBER	2	TNR15G431K
1-3*	0071706304	BEARING, 6304	1	2RUNYCM
2	7661017104	SET BOLT, ROTOR	1	
3	0801086104	SET WASHER, BEARING	1	
4	0040010000	SPRING WASHER	1	
5	7911340403	ARMATURE ASSY.	1	
6	7661315112	END BRACKET	1	
7	7871315022	END BRACKET	1	
8	7875021513	GUIDE PANEL, AIR	1	
9	7661331003	COVER	1	
10	7661344204	SET BOLT, STATOR	4	
11	0040008000	SPRING WASHER	4	
12	0041208000	PLAIN WASHER	4	
13	7871329514	GROMMET	1	
14	0601851760	CAP	1	
15	0017108020	HEX. HEAD BOLT	4	

GA-3.6RZ2 — CONTROL BOX ASSY.

CONTROL BOX ASSY.

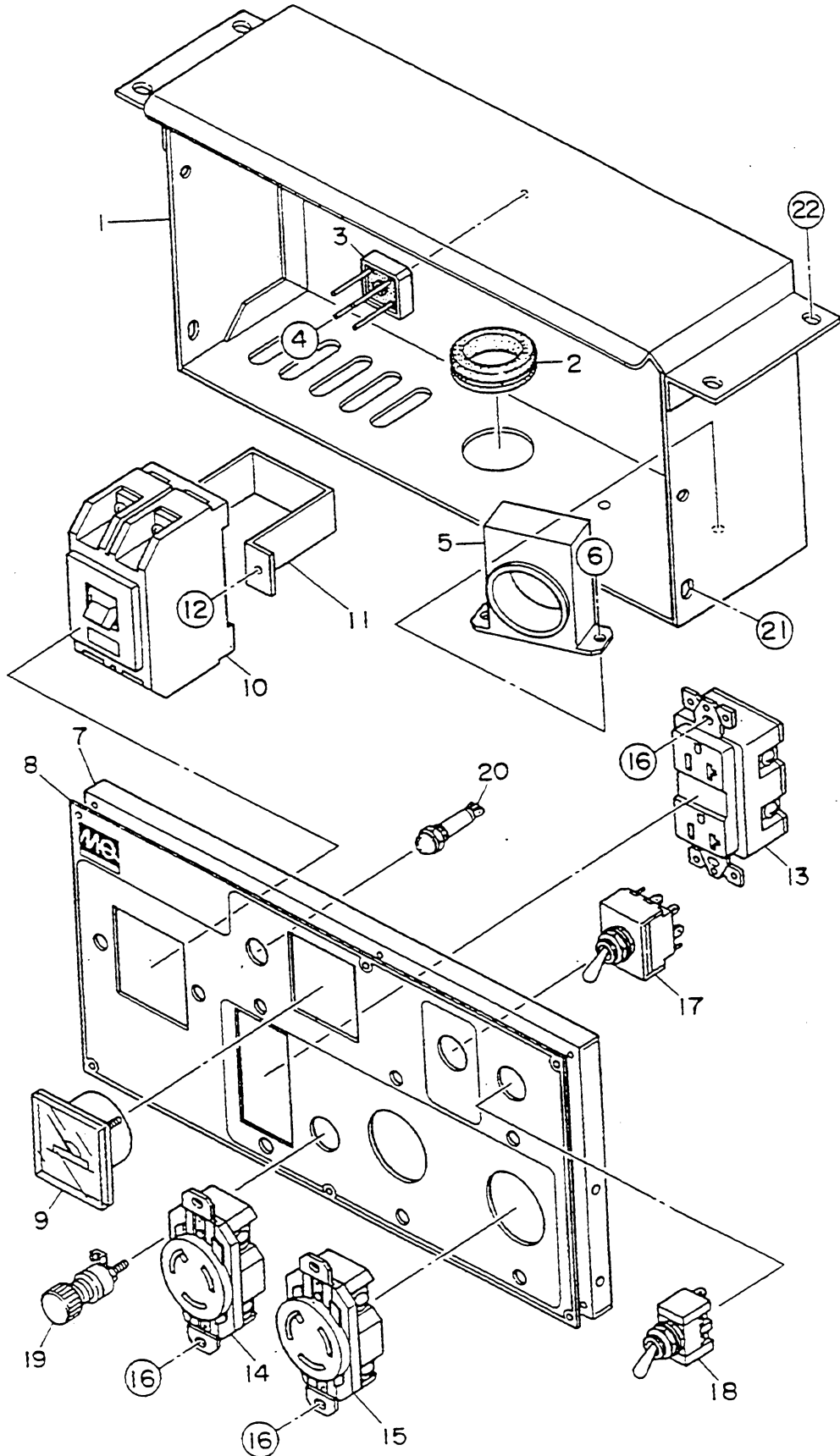

GA-3.6RZ2 — CONTROL BOX ASSY.

CONTROL BOX ASSY.

<u>NO</u>	<u>PART NO</u>	<u>PART NAME</u>	<u>QTY.</u>	<u>REMARKS</u>
1	7911811503	CONTROL BOX	1	UP TO S/N 5116919
	7911811513	CONTROL BOX	1	FROM S/N 5116920
2	0601850102	GROMMET	1	
3	0601823204	RECTIFIER	2	S5VB60
4	0027103020	MACHINE SCREW	2	
5	0601823853	SLOW DOWN UNIT	1	ND-80
6	0027104010	MACHINE SCREW	2	
	0027004000	HEX NUT	2	
7	7911821503	CONTROL PANEL	1	UP TO S/N 5116919
	7911821513	CONTROL PANEL	1	FROM S/N 5116920
8	7910501302	NAME PLATE	1	N-5641
9	0601800258	AC VOLTMETER	1	
10	0601805327	CIRCUIT BREAKER, 13.5A	1	
11	4341817004	BRACKET, CIRCUIT BREAKER	1	
12	0027104010	MACHINE SCREW	2	
13	0610811031	RECEPTACLE, 5-20R GFCI	1	REPLACES 0601811035
14	0601812597	RECEPTACLE, L5-30R,125V,30A	1	
15	0601811032	RECEPTACLE, L6-20R,250V,20A	1	
16	0027104010	MACHINE SCREW	6	
	0207004000	HEX NUT	6	
17	0601830737	FULL POWER SWITCH	1	ET330D12
18	0601830727	IDLE CONTROL SWITCH	1	ET115A12
19	0601815109	GROUND TERMINAL	1	
20	0602123555	OIL ALARM LAMP	1	06-106PR
21	0017105016	HEX. HEAD BOLT	4	
22	0017106016	HEX. HEAD BOLT	3	

GA-3.6RZ2 — PIPE FRAME ASSY.

PIPE FRAME ASSY.

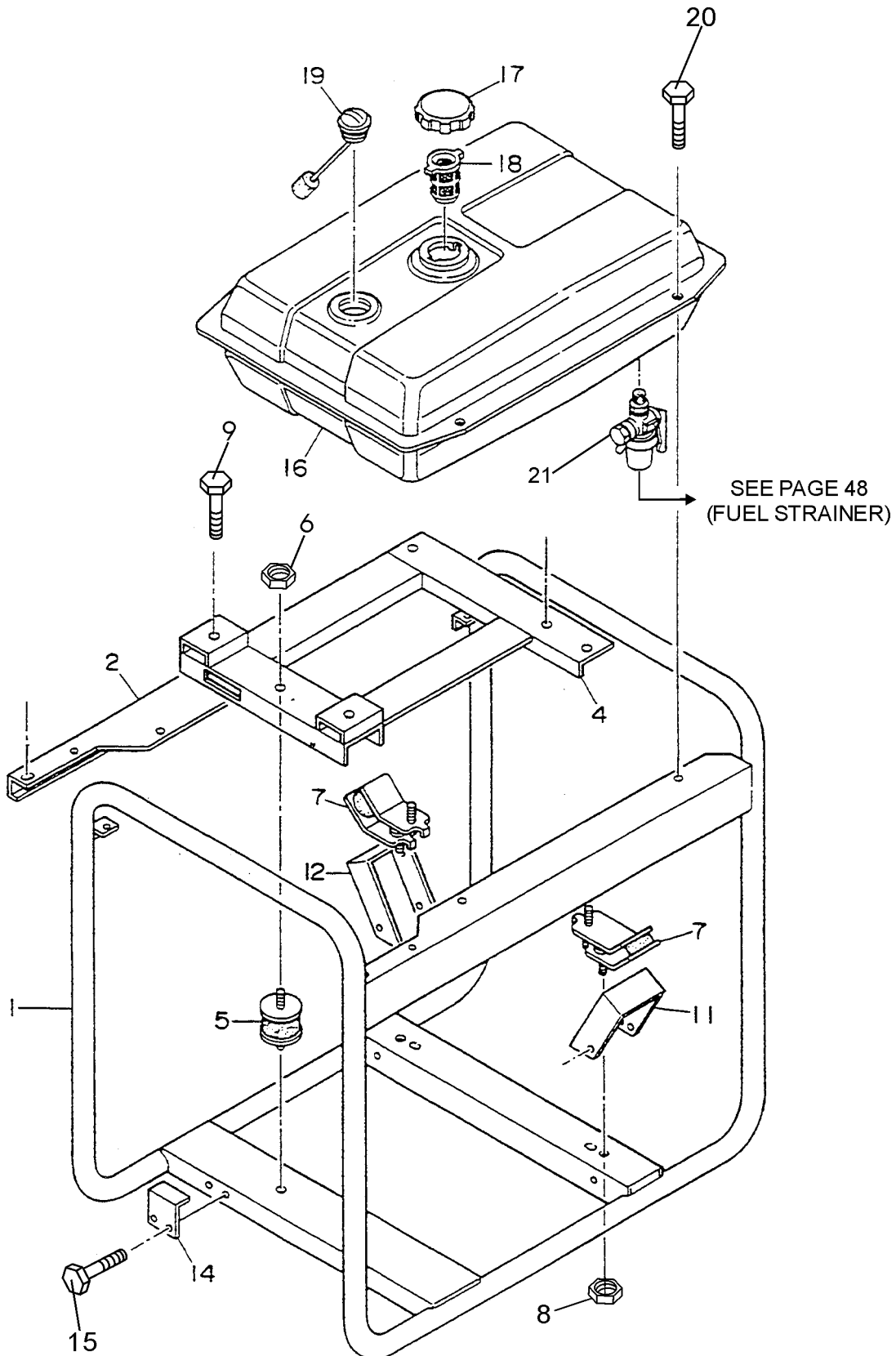

GA-3.6RZ2 — PIPE FRAME ASSY.

PIPE FRAME ASSY.

<u>NO</u>	<u>PART NO</u>	<u>PART NAME</u>	<u>QTY.</u>	<u>REMARKS</u>
1	7915411102	PIPE FRAME	1	UP TO S/N 5116919
	7915411112	PIPE FRAME	1	FROM S/N 5116920
2	7915414103	BRACKET	1	UP TO S/N 5116919
	7915414113	BRACKET	1	FROM S/N 5116920
3	0017106016	HEX,HEAD BOLT	2	
4	7915442103	BASE	1	
5	7895419004	RUBBER SUPENSION	1	
6	0207008000	HEX,NUT	2	
7	7685115504	RUBBER SUPENSION	2	
8	0207008000	HEX,NUT	4	
9	0017108030	HEX,HEAD BOLT	2	
	0207008000	HEX,NUT	2	
10	0017108040	HEX,HEAD BOLT	1	
	0207008000	HEX,NUT	1	
11	7915455003	COVER	1	
12	7915455103	COVER	1	
13	0017106016	HEX,HEAD BOLT	6	
14	7915456004	STOPPER	1	
15	0017106016	HEX, HEAD BOLT	2	
16	7945510102	FUEL, TANK	1	
17	0810106004	CAP, FUEL TANK	1	
18	0810107103	FUEL FILTER	1	
19	0602125031	FUEL GAUGE	1	
20	0017108020	HEX, HEAD BOLT	4	
21	0642008900	FUEL COCK	1	SEE PAGES 48 AND 49

GA-3.6RZ2 — NAME PLATE AND DECALS

NAME PLATE AND DECALS

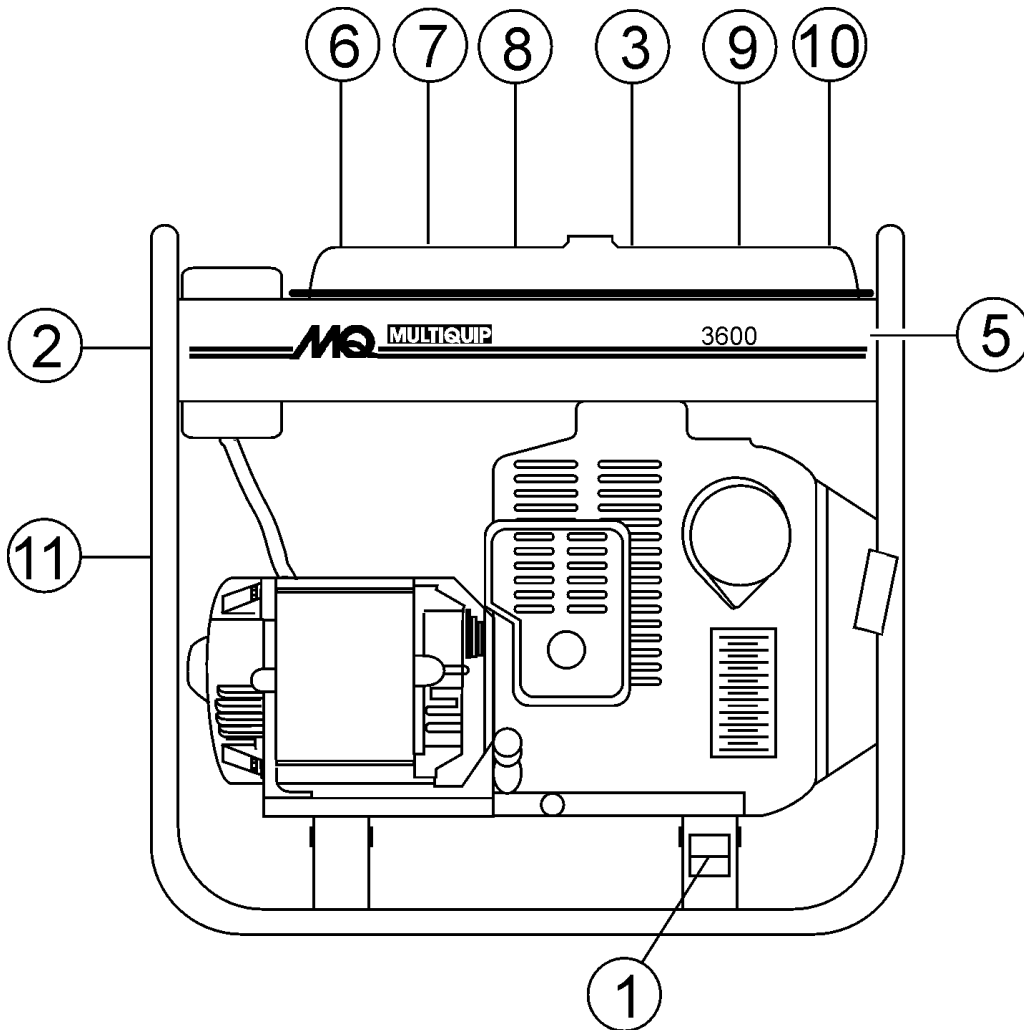

GA-3.6RZ2 — NAME PLATE AND DECALS

NAME PLATE AND DECALS

NO	PART NO	PART NAME	QTY.	REMARKS
1	0800628504	DECAL : GROUND	1	S-1123
2	1980680004	DECAL : FUEL COCK	1	S-3704
3	7900638204	DECAL : OPERATING INSTRUCTIONS	1	S-4605
4	7910501302	DECAL : MQ GA-3.6RZ2	1	S-5641
5	7910631002	DECAL : MQ 3600	1	S-3753
6	0820610804	DECAL : CAUTION	1	S-3311
7	0820610404	DECAL : WARNING	1	S-3627
8	7900636004	DECAL : OPERATE AT 3600 RPM ONLY	1	S-4461
9	8700611804	DECAL : WARNING	1	S-4984
10	8700611904	DECAL : DANGER	1	S-4985
11	DCLGA36RZ2	PLATE, SERIAL NO. KIT, DECAL	1	CONTACT MQ SERVICE DEPT. W/MODEL & S/N INCLUDES ITEMS W/*

SEE DECAL ILLUSTRATIONS ON PAGE 7.

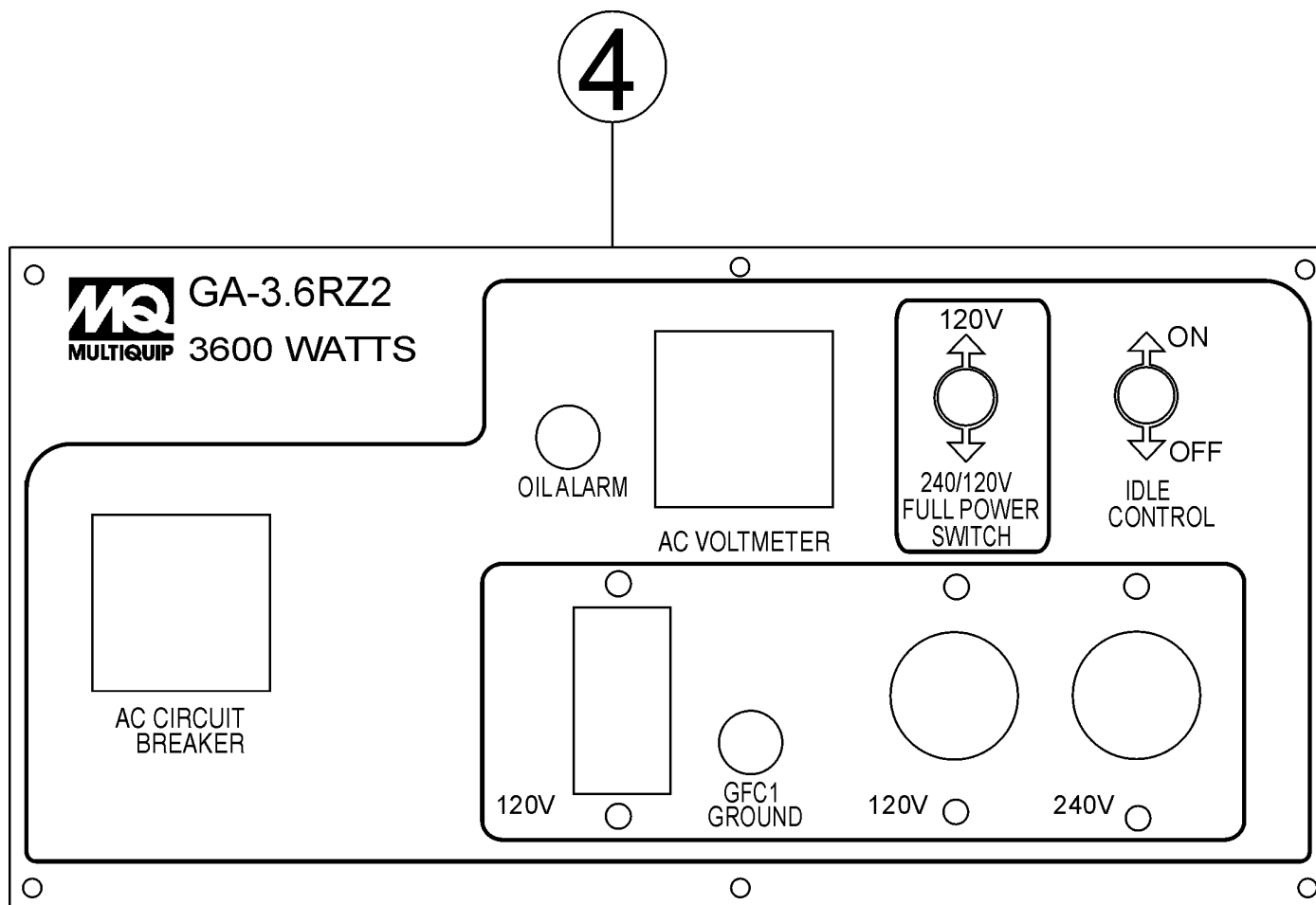

ROBIN EH-25 ENGINE — CRANKCASE ASSY.

CRANKCASE ASSY.

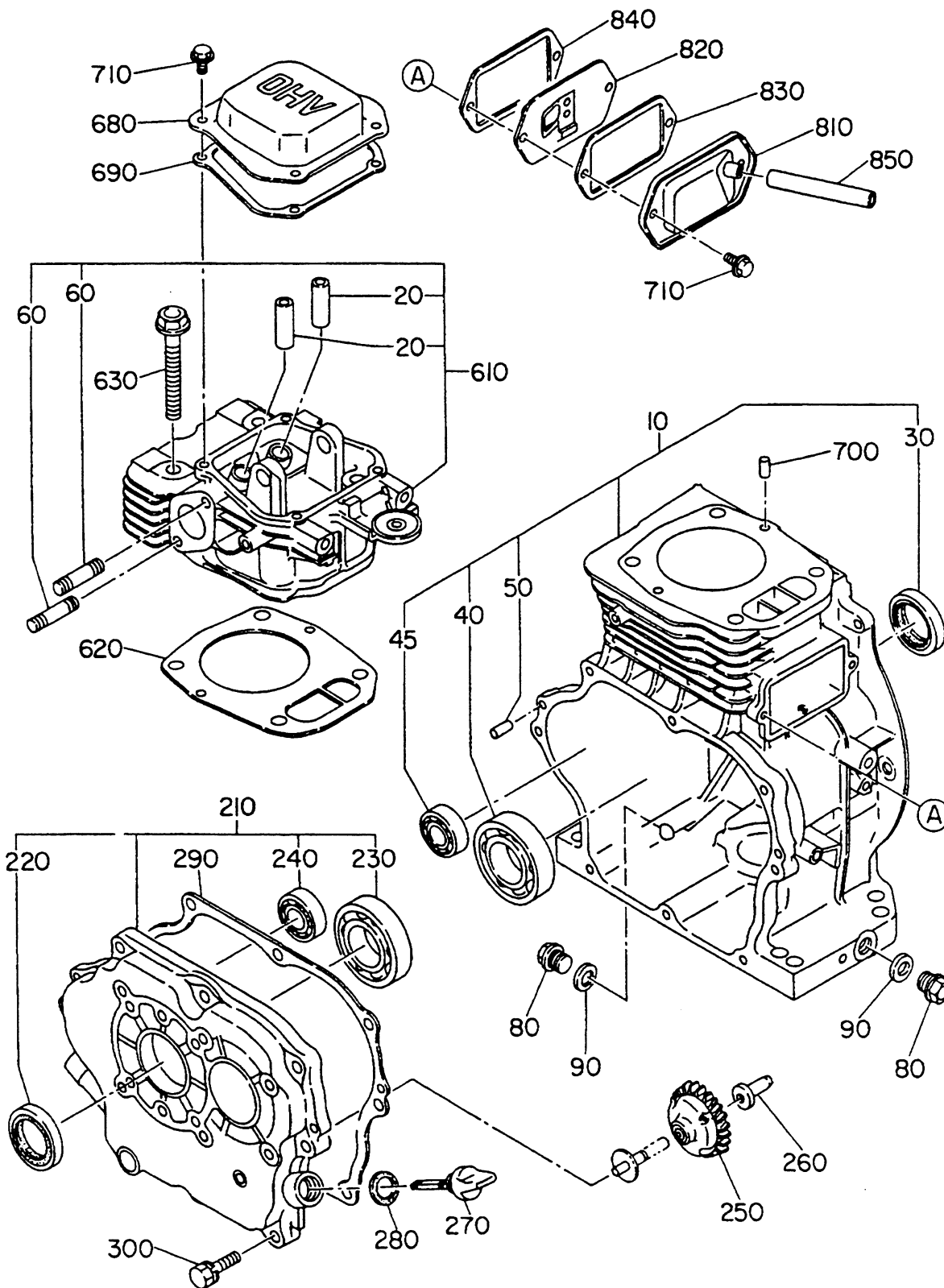

ROBIN EH-25 ENGINE — CRANKCASE ASSY.

CRANKCASE ASSY.

NO	PART NO	PART NAME	QTY.	REMARKS
10	2541010111	CRANKCASE	1	INCLS. ITEMS W/+ FROM S/N 1032215 TO 1032214
	2541010101	CRANKCASE	1	
20#	2461420203	VALVE GUIDE	2	
30+	0440300030	OIL SEAL	1	
40+	0600300220	BALL BEARING	1	
45+	0600150010	BALL BEARING	1	
50+	0310060020	DOWEL PIN	2	
60#	0013208500	STUD	2	
80	0401140030	PLUG	2	
90	0211140020	GASKET	2	
210	2541110301	MAIN BEARING COVER	1	INCLUDES ITEMS W/%
220%	0440300030	OIL SEAL	1	
230%	0600300220	BALL BEARING	1	
240%	0600150010	BALL BEARING	1	
250	2344500101	GOVERNOR GEAR	1	
260	2054190103	GOVERNOR SLEEVE	1	
270	2276360103	OIL GAUGE	1	
280*	0213160010	GASKET	1	
290*	2541600103	GASKET MA BEARING COVER	1	
300	0011308300	BOLT & WASHER	8	
610	2541300111	CYLINDER HEAD	1	INCLS. ITEMS W/# FROM S/N 1032215 TO 1032214
	2541300101	CYLINDER HEAD	1	
620*	2541500113	GASKET CYL HEAD	1	
630#	0110100040	FLANGE BOLT	4	
680	2541550103	ROCKET COVER	1	
690*	2541600503	GACKET ROCKET COVER	1	
700	0310060020	DOWEL PIN	2	
710	0110060020	FLANGE BOLT	6	
810	2541430101	BREATHER COVER	1	
820	2541440101	BREATHER PLATE	1	
830*	2461600603	GASKET BREATHER COVER	1	
840*	2461600703	GASKET BREATHER PLATE	1	
850	0851080000	RUBBER PIPE, 8X11X75 mm	1	
	2549900107	GASKET SET	1	INCLUDES ITEMS W/* ALSO INCLUDES GASKETS FROM THE INTAKE & EXHAUST ASSY. ON PAGES 38 & 39 ITEMS 340, 555 & 560.

ROBIN EH-25 ENGINE — CRANKSHAFT & PISTON ASSY.

CRANKSHAFT & PISTON ASSY.

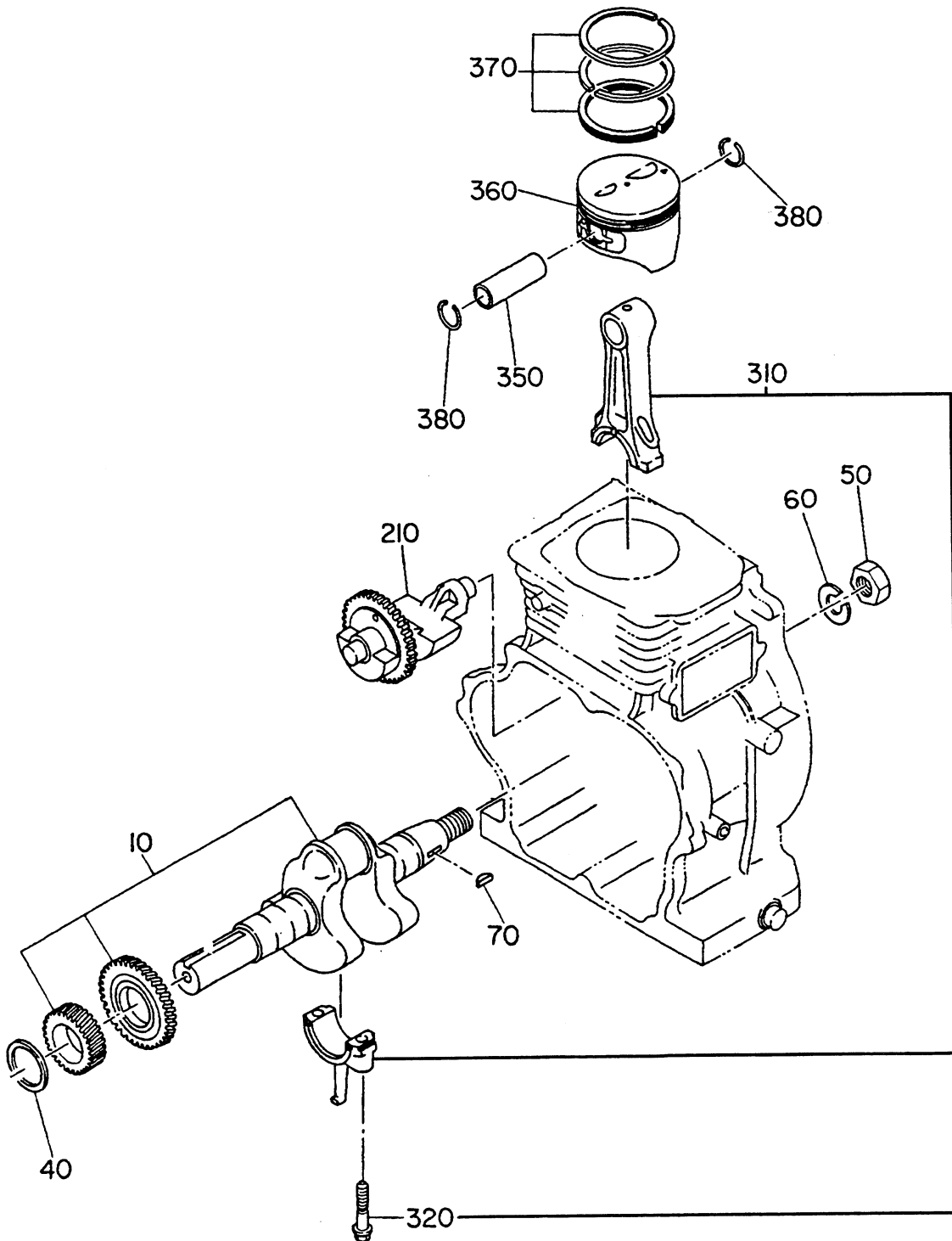

ROBIN EH-25 ENGINE — CRANKSHAFT & PISTON ASSY.

CRANKSHAFT & PISTON ASSY.

<u>NO</u>	<u>PART NO</u>	<u>PART NAME</u>	<u>QTY.</u>	<u>REMARKS</u>
10	2542090101	CRANKSHAFT, STD 1IN. KEYED	1	
40	0230300170	SPACER T =0.6 mm	1	
	0230300180	SPACER T =0.8 mm	1	
	0230300190	SPACER T =1.0 mm	1	
50	0021818000	NUT	1	
60	0032018000	SPRING WASHER	1	
70	0323030010	WOODRUFF KEY	1	
210	2542410103	BALANCER SHAFT	1	
310	2542250100	CONNECTING ROD	1	INCLUDES ITEMS W/*
320*	2462300103	CONN ROD BOLT	2	
350	2542330103	PISTON PIN	1	
360	2542340103	PISTON	1	
	2542340203	PISTON, 0.25 mm	1	
	2542340303	PISTON, 0.50 mm	1	
370	2542350107	PISTON RING SET	1	
	2542350207	PISTON RING SET, 0.25 mm	1	
	2542350307	PISTON RING SET, 0.50 mm	1	
380	0565180010	CLIP	2	

ROBIN EH-25 ENGINE — INTAKE & EXHAUST ASSY.

INTAKE & EXHAUST ASSY.

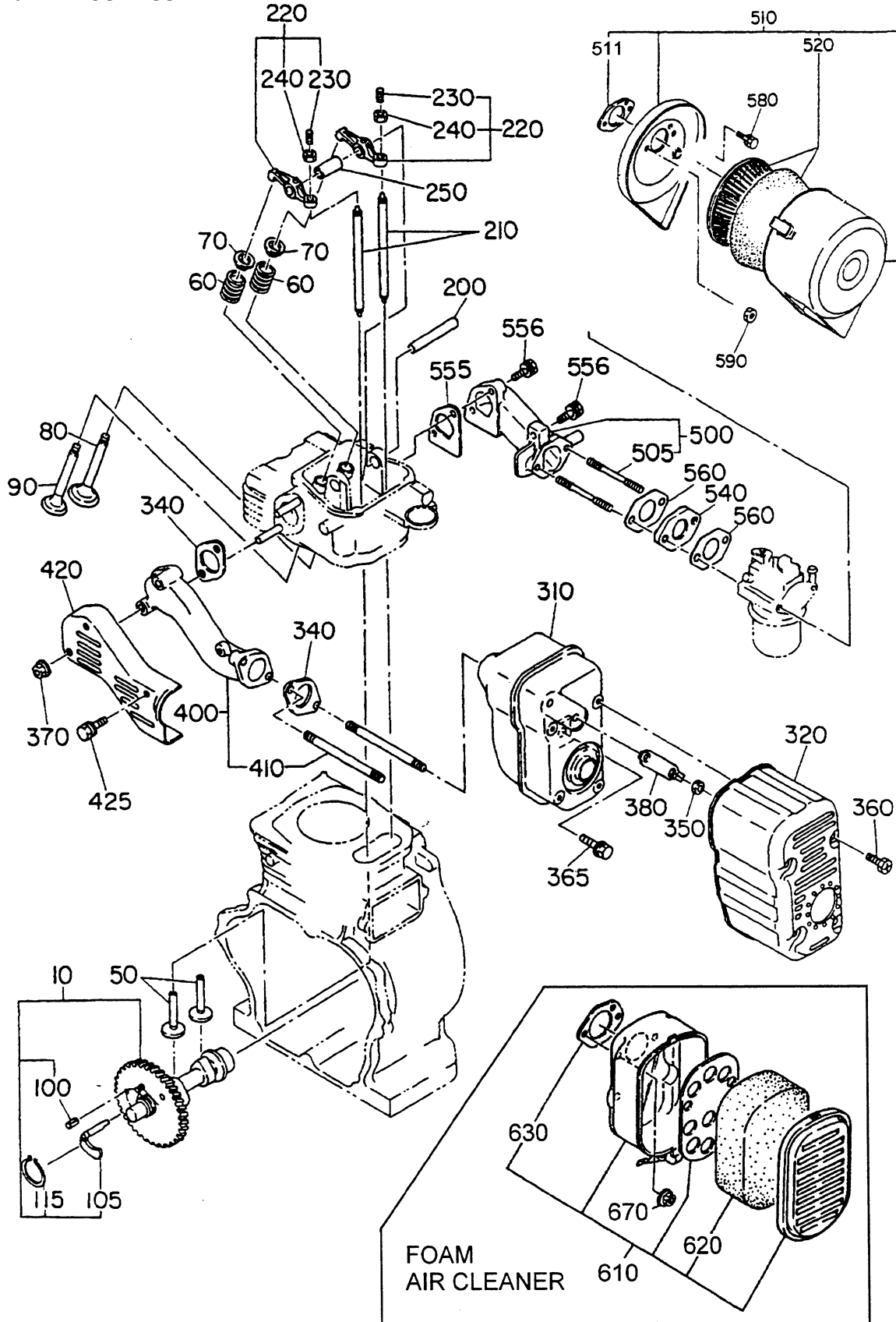

ROBIN EH-25 ENGINE — INTAKE & EXHAUST ASSY.

INTAKE & EXHAUST ASSY.

<u>NO</u>	<u>PART NO</u>	<u>PART NAME</u>	<u>QTY.</u>	<u>REMARKS</u>
10	2543170101	CAMSHAFT	1	INCLUDES ITEMS W/#
50	2543330103	TAPPET	2	
60	2543360103	VALVE SPRING	2	
70	2463370113	SPRING RETAINER	2	
80	2543340103	INTAKE VALVE	1	
90	2543350103	EXHAUST VALVE	1	
100#	0051904100	SPRING PIN	1	
105#	2543640103	RELEASE LEVER	1	
115#	0031522000	SNAP RING	1	
200	2393500103	ROCKER SHAFT	1	
210	2463610110	PUSH ROD	2	REPLACES 2483530111
220	2463610110	ROCKER ARM	2	INCLUDES ITEMS W/*
230*	0149080021	ADJUSTING SCREW	2	
240*	0170080090	NUT	2	
250	2543612013	SPACER	1	
310	25430410101	MUFFLER	1	
320	2543420101	MUFFLER COVER	1	
340	2463520103	GASKET MUFFLER	2	
350	0170080030	NUT	2	
360	0152050010	TAPPING SCREW	4	
365	0011008160	BOLT& WASHER	1	
370	0180080010	FLANGE NUT	2	
380	2543610103	LOCK WASHER	1	
400	2543400101	EXHAUST PIPE	1	INCLUDES ITEMS W/+
410+	0105080410	STUD	2	
420	2543480101	EXHAUST PIPE COVER	1	
425	0110060050	FLANGE BOLT	1	REPLACES 0110060010
500	2543300101	INTAKE PIPE	1	INCLUDES ITEMS W/%
505%	0105060190	STUD	2	REPLACES 0105060191
510	2543260210	AIR CLEANER ASSY.	1	INCLUDES ITEMS W/■
511■	2343600308	PACKING	1	
520■	2343260407	ELEMENT	1	
540	2343290103	INSULATOR	1	
555	2463600113	GASKET INPIPE	1	
556	0011308280	BOLT& WASHER	3	
560	2343590203	GASKET 2 (INSULATOR)	2	
580	0011006120	BOLT& WASHER	1	
590	2263921200	NUT & WASHER	2	
610	2393260110	AIR CLEANER ASSY.	1	INCLUDES ITEMS W/\$
620\$	2343600203	ELEMENT	1	
630\$	2343600303	GASKET	1	
670	0023706000	FLANGE NUT	2	REPLACES 0023806000

ROBIN EH-25 ENGINE — GOVERNOR ASSY.

GOVERNOR ASSY.

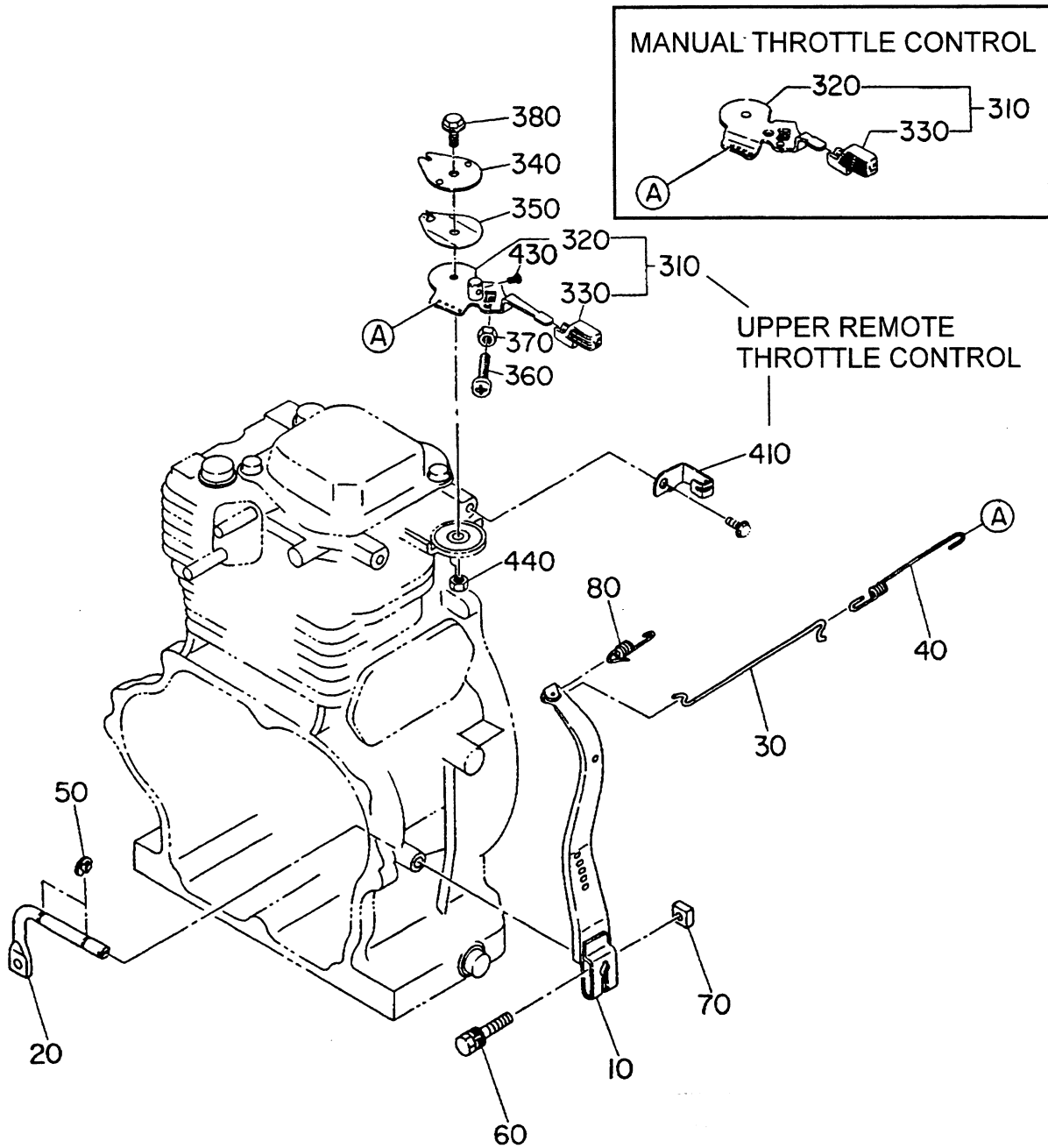

ROBIN EH-25 ENGINE — GOVERNOR ASSY.

GOVERNOR ASSY.

<u>NO</u>	<u>PART NO</u>	<u>PART NAME</u>	<u>QTY.</u>	<u>REMARKS</u>
10	2544230101	GOVERNOR LEVER	1	
20	2464220103	GOVERNOR SHAFT	1	
30	2544270101	GOVERNOR ROD	1	
40	2544280103	ROD SPRING	1	
50	0031306000	CLIP	2	
60	0011406250	BOLT & WASHER	1	
70	0186060020	NUT	1	
80	2544250113	GOVERNOR SPRING	1	
310	2274330200	SPEED CONTROL ASSY.	1	INCLUDES ITEMS W/*
320*	2274330201	SPEED CONTROL CP	1	
330*	2274360103	KNOB	1	
340	2274350113	STOP PLATE	1	REPLACES 2274350101
350	2274500203	SPRING WASHER	1	
360	0043106300	SCREW PANHEAD	1	
370	020106050	NUT	1	REPLACES 0022706000
380	0110060050	FLANGE BOLT	1	
410	2544420001	WIRE BRACKET	1	
430	0043500480	SCREW PANHEAD	1	REPLACES 0043104080
440	020106050	NUT	1	REPLACES 0022706000

ROBIN EH-25 ENGINE — COOLING & STARTING ASSY.

COOLING & STARTING ASSY.

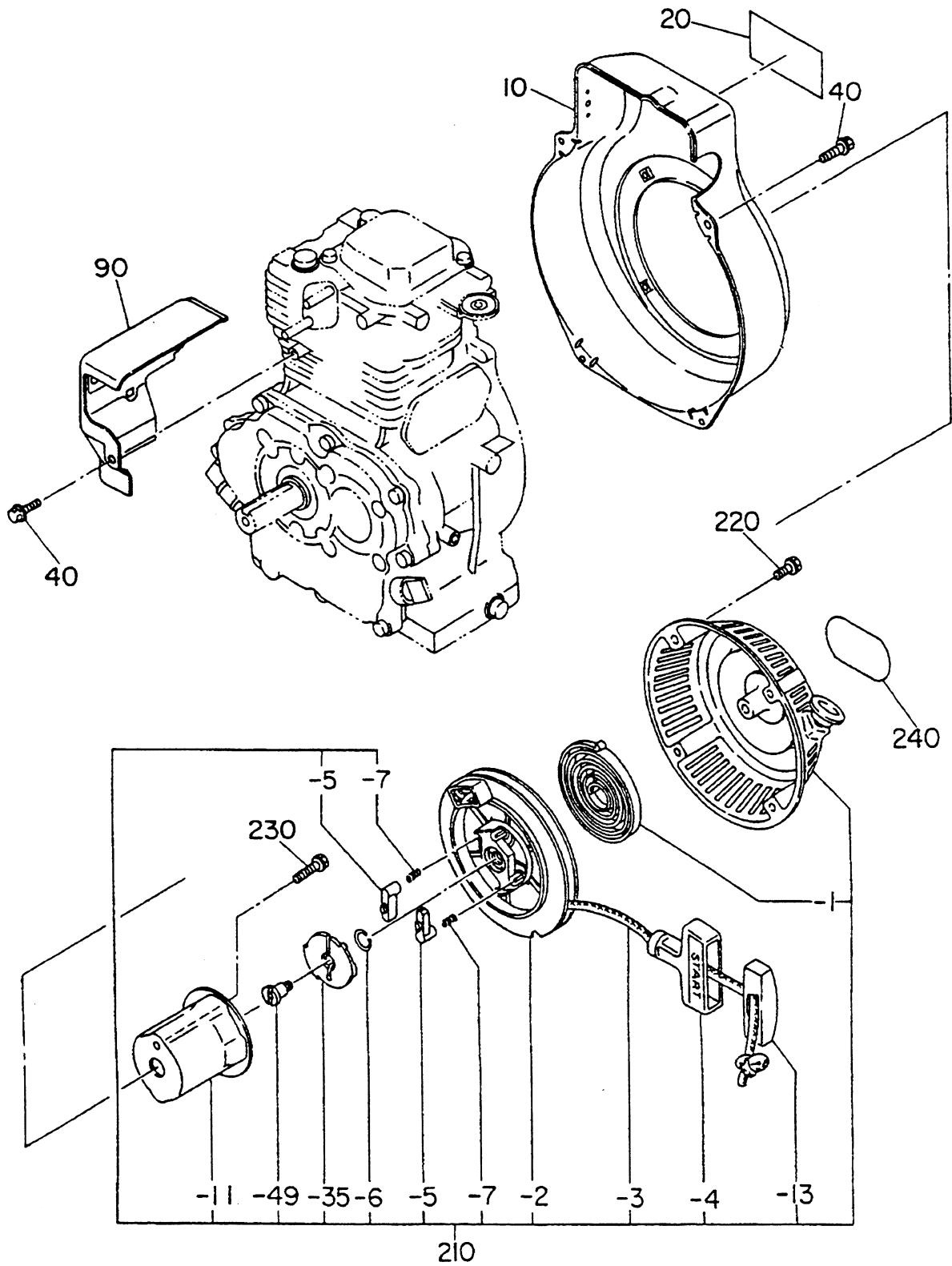

ROBIN EH-25 ENGINE — COOLING & STARTING ASSY.

COOLING & STARTING ASSY.

<u>NO</u>	<u>PART NO</u>	<u>PART NAME</u>	<u>QTY.</u>	<u>REMARKS</u>
10	2545345101	BLOWER HOUSING, BLACK	1	
20	2549170303	LABEL TRADE MARK	1	
40	0110060020	FLANGE BOLT	5	
90	2545270103	HEAD COVER	1	
210	2545020100	RECOIL STARTER	1	INCLUDES ITEMS W/ *
210-1*	2155051508	SPIRAL SPRING	1	
210-2*	2345012018	REEL	1	
210-3*	1065011308	STARTER ROPE	1	
210-4*	2265010008	STARTER KNOB	1	
210-5*	1615012508	RATCHET	2	
210-6*	2275013108	FRICTION SPRING	1	
210-7*	2275013508	RETURN SPRING	2	
210-11*	2545014508	PULLEY	1	
210-13*	2275015008	KNOB CAP	1	
210-35*	1615015008	RATCHET GUIDE	1	
210-49*	2275015208	SET SCREW	1	
220	0110060010	FLANGE BOLT	4	
230	0110060030	FLANGE BOLT	1	
240	0732004350	LABEL OHV	1	

ROBIN EH-25 ENGINE — CARBURETOR ASSY.

CARBURETOR ASSY.

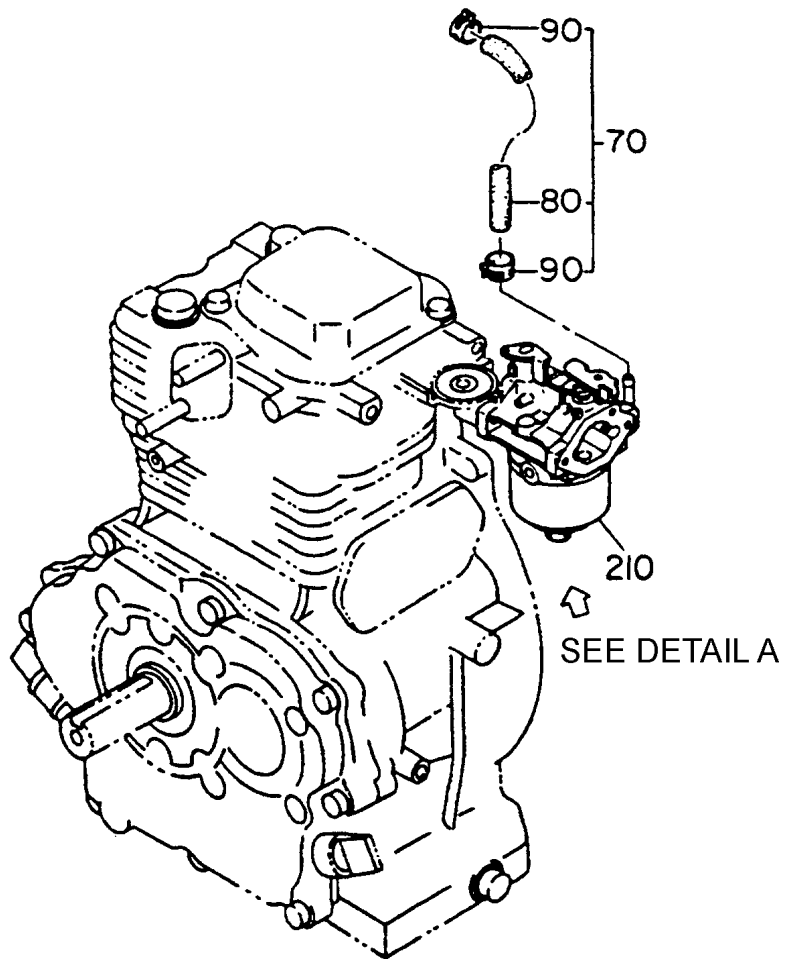
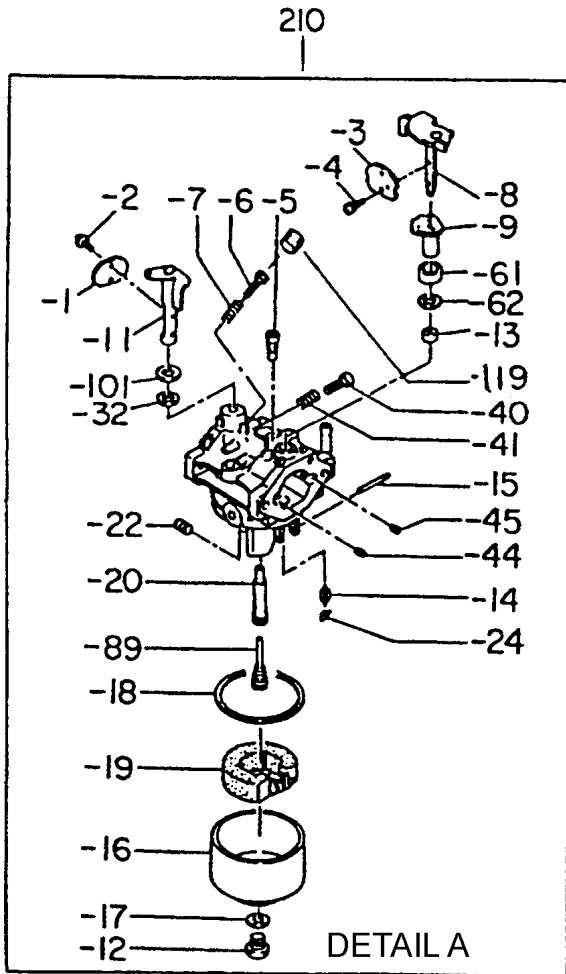

ROBIN EH-25 ENGINE — CARBURETOR ASSY.

CARBURETOR ASSY.

<u>NO</u>	<u>PART NO</u>	<u>PART NAME</u>	<u>QTY.</u>	<u>REMARKS</u>
70	2346260101	FUEL PIPE	1	INCLUDES ITEMS W/#
80#	0851060230	RUBBER PIPE, 6X12X70mm	1	REPLACES 0851060000
90#	1561110020	HOSE CLAMP	2	
210	2536240400	CARBURETOR	1	INCLUDES ITEMS W/ *
210-1*	2206253608	THROTTLE VALVE	1	
210-2*	2376245108	SCREW	2	
210-3*	2366252808	CHOKE VALVE	1	
210-4*	2376245108	SCREW	2	
210-5*	2536242008	PILOT JET	1	
210-6*	2466243608	PILOT SCREW	1	
210-7*	2096244508	SPRING	1	
210-8*	2366252008	CHOKE LEVER	1	
210-9*	2396256008	RING	1	
210-11*	2366260008	THROTTLE SHAFT	1	
210-12*	2366245108	BOLT	1	
210-13*	2266255008	RING	1	
210-14*	1616235208	NEEDLE	1	
210-15*	2366251008	PIN	1	
210-16*	2366255108	FLOAT CHAMBER BODY	1	
210-17*	2366245008	PACKING	1	
210-18*	2366254008	PACKING	1	
210-19*	5806083350	FLOAT	1	REPLACES 2366250508
210-20*	2386244008	MAIN NOZZLE	1	
210-22*	2536240108	MAIN JET	1	
210-32*	5806083210	SEAL	1	REPLACES 1066239208
210-40*	2466243508	ADJUSTING SCREW	1	
210-41*	2366244508	SPRING	1	
210-61*	2476255008	CAP CHOKE	1	
210-62*	2366268008	SEAL	1	
210-89*	2356242508	GUIDE HOLDER	1	
210-101*	2366263108	RING	1	
210-119*	2466255108	CAP	1	

ROBIN EH-25 ENGINE — IGNITION COIL ASSY. AND SPARK PLUG

IGNITION COIL ASSY. AND SPARK PLUG

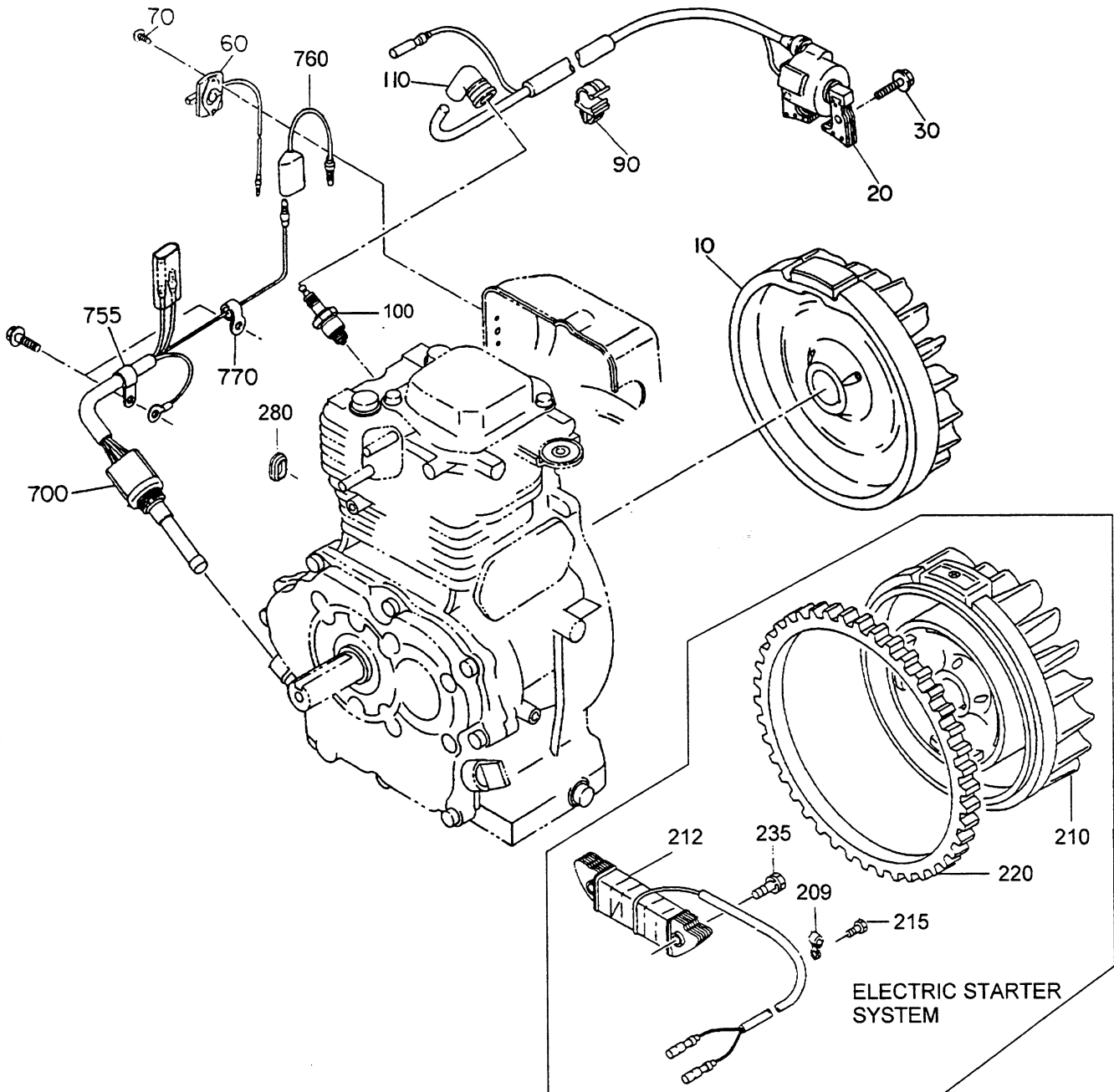

ROBIN EH-25 ENGINE — IGNITION COIL ASSY. AND SPARK PLUG

IGNITION COIL ASSY. AND SPARK PLUG

<u>NO</u>	<u>PART NO</u>	<u>PART NAME</u>	<u>QTY.</u>	<u>REMARKS</u>
10	2347012108	FLY WHEEL	1	
20	2547013018	IGNITION COIL	1	REPLACES 2547943011
30	0043506250	BOLT & WASHER	2	
60	0669900217	SWITCH	1	REPLACES 0669900207
70	0150040090	TAPPING SCREW	2	
90	0566000250	CLAMP	1	
95	0659000010	PLUG TERMINAL	1	
100	0650140150	SPARK PLUG	1	REPLACES 0650141030
110	0655000051	PLUG CAP	1	
209	2067550101	CLAMP	1	
210	2347020301	FLYWHEEL	1	
212	2277963201	CHARGING COIL	1	
215	0110060010	FLANGE BOLT	1	
220	2547100203	RING GEAR	1	
235	0043506250	SCREW & WASHER	2	
280	2267550103	GROMMET	1	
700	KS31102301	OIL SENSOR	1	
755	2147900301	CLAMP	1	
760	2147312201	WIRE 22	1	
770	0566120050	CLAMP	1	

ROBIN EH-25 ENGINE — FUEL STRAINER

FUEL STRAINER ASSY.

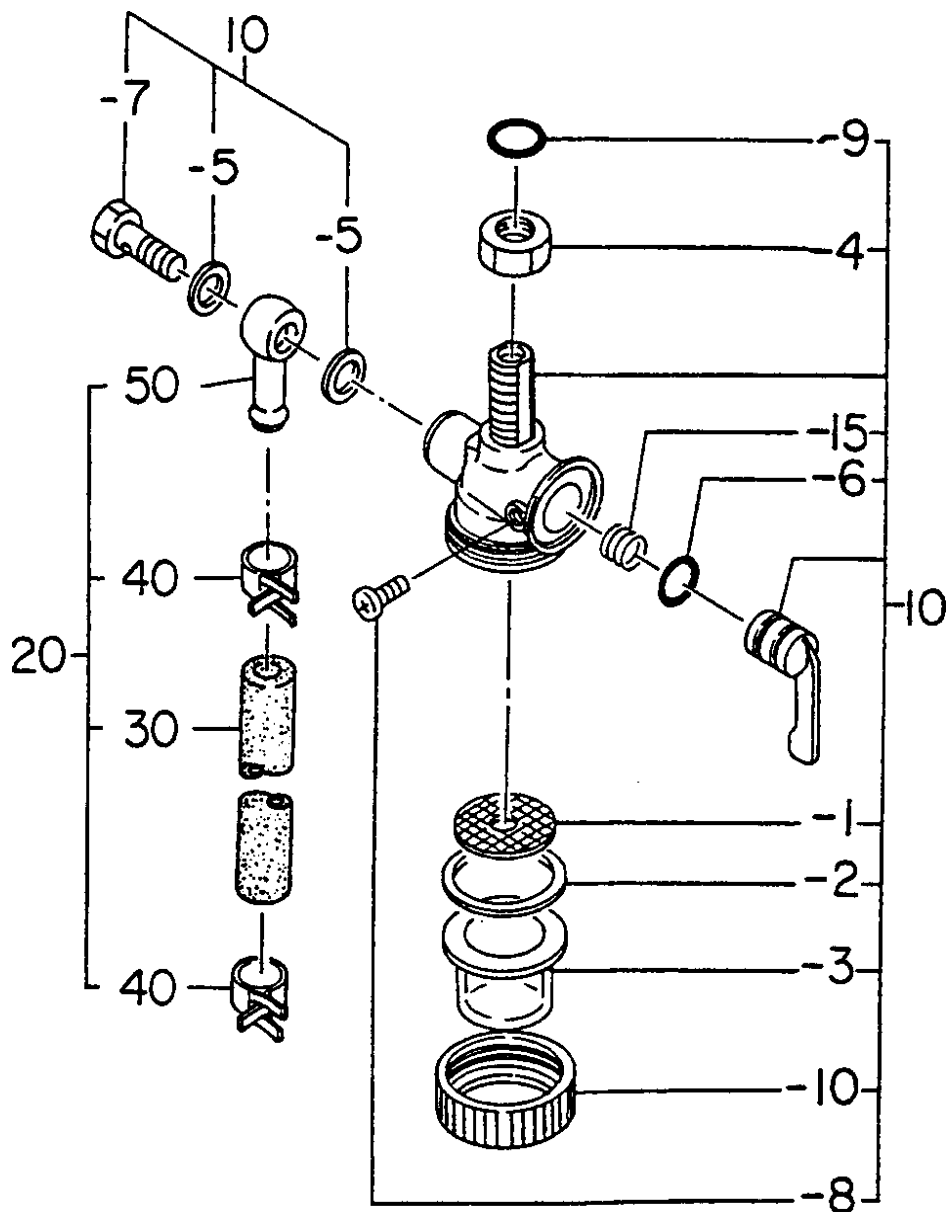

ROBIN EH-25 ENGINE — FUEL STRAINER

FUEL STRAINER ASSY.

<u>NO.</u>	<u>PART NO.</u>	<u>PART NAME</u>	<u>QTY.</u>	<u>REMARKS</u>
10	0642008900	FUEL STRAINER ASSY.	1	INCLUDES ITEMS W/# REPLACES 0605510024
10-1#	0642000220	FILTER	1	
10-2#	0642000230	GASKET	1	
10-3#	0642001910	CUP (NYLON)	1	
10-4#	0642002360	LOCK NUT	1	
10-5#	0642000250	GASKET	2	
10-6#	0642000330	O--RING	1	
10-7#	0642000240	BANJO BOLT	1	
10-8#	0642002790	LOCK BOLT	1	
10-9#	0642000330	O--RING	1	
10-10#	0642002410	LOCK NUT	1	
10-15#	0642003230	SPRING	1	
20	2696260401	FUEL PIPE 4 CP	1	INCLUDES ITEMS W/*
30*	2696800403	RUBBER PIPE	1	
40*	0561110020	HOSE CLAMP	2	
50*	0521070042	BANJO	1	

PAYMENT TERMS

Terms of payment for parts are net 10 days.

FREIGHT POLICY

All parts orders will be shipped collect or prepaid with the charges added to the invoice. All shipments are F.O.B. point of origin. Multiquip's responsibility ceases when a signed manifest has been obtained from the carrier, and any claim for shortage or damage must be settled between the consignee and the carrier.

MINIMUM ORDER

The minimum charge for orders from Multiquip is \$15.00 net. Customers will be asked for instructions regarding handling of orders not meeting this requirement.

RETURNED GOODS POLICY

Return shipments will be accepted and credit will be allowed, subject to the following provisions:

1. A Returned Material Authorization must be approved by Multiquip prior to shipment.
2. To obtain a Return Material Authorization, a list must be provided to Multiquip Parts Sales that defines item numbers, quantities, and descriptions of the items to be returned.
 - a. The parts numbers and descriptions must match the current parts price list.
 - b. The list must be typed or computer generated.
 - c. The list must state the reason(s) for the return.
 - d. The list must reference the sales order(s) or invoice(s) under which the items were originally purchased.
 - e. The list must include the name and phone number of the person requesting the RMA.
3. A copy of the Return Material Authorization must accompany the return shipment.

4. Freight is at the sender's expense. All parts must be returned freight prepaid to Multiquip's designated receiving point.
5. Parts must be in new and resalable condition, in the original Multiquip package (if any), and with Multiquip part numbers clearly marked.
6. The following items are not returnable:
 - a. Obsolete parts. (If an item is listed in the parts price book as being replaced by another item, it is obsolete.)
 - b. Any parts with a limited shelf life (such as gaskets, seals, "O" rings, and other rubber parts) that were purchased more than six months prior to the return date.
 - c. Any line item with an extended dealer net price of less than \$5.00.
 - d. Special order items.
 - e. Electrical components.
 - f. Paint, chemicals, and lubricants.
 - g. Decals and paper products.
 - h. Items purchased in kits.
7. The sender will be notified of any material received that is not acceptable.
8. Such material will be held for 5 working days from notification, pending instructions. If a reply is not received within 5 days, the material will be returned to the sender at his expense.
9. Credit on returned parts will be issued at dealer net price at time of the original purchase, less a 15% restocking charge.
10. In cases where an item is accepted for which the original purchase document can not be determined, the price will be based on the list price that was effective twelve months prior to the RMA date.
11. Credit issued will be applied to future purchases only.

PRICING AND REBATES

Prices are subject to change without prior notice. Price changes are effective on a specific date and all orders received on or after that date will be billed at the revised price. Rebates for price declines and added charges for price increases will not be made for stock on hand at the time of any price change.

Multiquip reserves the right to quote and sell direct to Government agencies, and to Original Equipment Manufacturer accounts who use our products as integral parts of their own products.

SPECIAL EXPEDITING SERVICE

A \$20.00 to \$50.00 surcharge will be added to the invoice for special handling including bus shipments, insured parcel post or in cases where Multiquip must personally deliver the parts to the carrier.

LIMITATIONS OF SELLER'S LIABILITY

Multiquip shall not be liable here under for damages in excess of the purchase price of the item with respect to which damages are claimed, and in no event shall Multiquip be liable for loss of profit or good will or for any other special, consequential or incidental damages.

LIMITATION OF WARRANTIES

No warranties, express or implied, are made in connection with the sale of parts or trade accessories nor as to any engine not manufactured by Multiquip. Such warranties made in connection with the sale of new, complete units are made exclusively by a statement of warranty packaged with such units, and Multiquip neither assumes nor authorizes any person to assume for it any other obligation or liability whatever in connection with the sale of its products. A part from such written statement of warranty, there are no warranties, express, implied or statutory, which extend beyond the description of the products on the face hereof.

PARTS AND OPERATION MANUAL

HERE'S HOW TO GET HELP

*PLEASE HAVE THE MODEL AND SERIAL NUMBER
ON-HAND WHEN CALLING*

PARTS DEPARTMENT

800-427-1244 or 310-537-3700

FAX: 800-672-7877 or 310-637-3284

SERVICE DEPARTMENT/TECHNICAL ASSISTANCE

800-478-1244 or 310-537-3700

FAX: 310- 537-4259

WARRANTY DEPARTMENT

888-661-4279, or 310-661-4279

FAX: 310- 537-1173

MAIN

800-421-1244 or 310-537-3700

FAX: 310-537-3927

Manufactured for MULTIQUIP INC.
by
DENYO MANUFACTURING CO., JAPAN



MULTIQUIP INC.
POST OFFICE BOX 6254
CARSON, CA 90749
310-537-3700 • 800-421-1244
FAX: 310-537-3927
E-MAIL: mq@multiquip.com
WWW: multiquip.com

Atlanta • Boise • Dallas • Houston • Newark
Quebec, Canada • Manchester, UK • Rio De Janeiro, BR • Guadalajara, MX